

Nuclear Physics Graduate Schools



Fall 2016

This brochure was compiled by M. Caplan and M. Thoennesen for the Committee on Education of the APS Division of Nuclear Physics.

If you would like to add a program please send an email to ceu-contact@nscl.msu.edu

Contents:

| | |
|--|----|
| Arizona, University of | 5 |
| Arizona State University | 7 |
| California, University of, Los Angeles | 9 |
| California, University of, Davis | 11 |
| Central Michigan University | 13 |
| Colorado, University of, Boulder | 15 |
| Colorado School of Mines | 17 |
| Connecticut, University of | 19 |
| Creighton University | 21 |
| Duke University | 23 |
| Florida International University | 25 |
| George Washington University | 27 |
| Georgia State University | 29 |
| Hampton University | 31 |
| Idaho, University of | 33 |
| Illinois, University of, Chicago | 35 |
| Indiana University | 37 |
| Iowa, University of | 39 |
| Iowa State University | 41 |
| Kentucky, University of | 43 |
| Louisiana State University | 45 |
| Massachusetts, University of, Amherst | 47 |
| Massachusetts, University of, Lowell | 49 |
| Michigan, University of | 51 |
| Michigan State University | 53 |
| Minnesota, University of | 55 |

| | |
|--|-----|
| Mississippi State University | 57 |
| Massachusetts Institute of Technology | 59 |
| North Carolina State University | 61 |
| New Mexico State University | 63 |
| North Carolina, University of, Chapel Hill | 65 |
| Notre Dame, University of | 67 |
| Ohio University | 69 |
| Ohio State University | 71 |
| Old Dominion University | 73 |
| Purdue University | 75 |
| South Carolina, University of | 77 |
| Stony Brook University | 79 |
| Texas A&M University | 81 |
| Temple University | 83 |
| Tennessee, University of, Knoxville | 85 |
| Tulane University | 87 |
| Vanderbilt University | 89 |
| Washington, University of, Seattle | 91 |
| Washington University in St Louis | 93 |
| Wayne State University | 95 |
| William and Mary, College of | 97 |
| Wisconsin, University of, Madison | 99 |
| Yale University | 101 |



THE UNIVERSITY OF ARIZONA®

Nuclear Theory



The nuclear theory group at the University of Arizona carries out research into the structure and behavior of strongly interacting matter in terms of its basic constituents--quarks and gluons--over a wide range of conditions: from nucleons and nuclear matter to the cores of stars, and from the Big Bang that was the birth of the Universe to the heavy-ion collisions in present-day experiments.

Currently the UA Nuclear Physics Group consists of ten graduate students, three postdoctoral fellows, and five full time faculty.

Faculty



Bruce Barrett

My research interest centers on nuclear-structure theory, mainly on microscopic theories of nuclear structure utilizing the large-basis, no-core shell-model approach and the quantum many-body theory of effective interactions and operators. Other investigations include the microscopic interpretation of the Interacting Boson Model for nuclear collective motion and its applications and extensions.

bbarrett@physics.arizona.edu

<http://www.physics.arizona.edu/physics/personnel/faculty/barrettbio.html>



Sean Fleming

My research focuses on the development and application of effective field theories to quantum chromodynamics (QCD). The effective theories I develop and work with result in a simpler and more predictive framework. I have worked on non-relativistic effective theories of the strong interactions (NRQCD), an effective theory of heavy nucleons coupled to pions, heavy-quark effective theory (HQET), and soft collinear effective theory (SCET).

fleming@physics.arizona.edu

<http://www.physics.arizona.edu/~fleming/>



Johann Rafelski

How was matter created in the Universe? My research explores the physics of quark-gluon plasma (QGP) and its signature: strangeness, with the objective to understand the matter production mechanisms. This relates to QCD vacuum structure, where my current interest is the exploration of the response to strong external EM fields, generated by ultra short laser pulses. This effort leads on to the phenomenon of strong field induced dark energy. We also study related topics such as electromagnetic plasma in MeV temperature range, and quantum transport. We use all the above in the study of the cosmological era after matter is formed from QGP.

rafelski@physics.arizona.edu

<http://www.physics.arizona.edu/~rafelski/>



Douglas Toussaint

Dr. Toussaint's research involves the use of massively parallel computers to calculate some of the most fundamental quantities in high energy physics. He employs lattice gauge theory to calculate the masses and lifetimes of strongly interacting particles, the weak interactions of these particles, the behavior of nuclear matter at very high temperatures, and the structure of the electroweak interactions.

doug@physics.arizona.edu

<http://www.physics.arizona.edu/~doug/>



Bira van Kolck

My research interests are on Effective Field Theories applied to particle, nuclear, atomic, and molecular physics. Emphasis is on the development of systematic low-energy expansions allowing for an understanding of bound states. Of particular interest are nuclei. The goal is to eventually predict the properties of light nuclei and nuclear matter at finite temperature from the underlying theory of strong interactions, QCD.

vankolck@physics.arizona.edu

<http://www.physics.arizona.edu/~vankolck/>

Nuclear Physics at UA:

http://www.physics.arizona.edu/physics2006/research.php?page=nuclear_physics

Applications For UA Physics Graduate Program:

http://www.physics.arizona.edu/physics2006/graduate.php?page=application_procedure

Graduate Studies in Nuclear Physics and Particle Astrophysics at Arizona State University



Physics People:

Faculty: 39
Ph.D. Students: 110
Undergraduate majors: 248

Ph.D. Program:

First-year research rotations
Comprehensive exams after first year

Graduate Research Areas:

Biophysics and Biological Physics
Nanoscience and Materials Physics
Nuclear Physics, Particle
Astrophysics and Cosmology
Physics and Society

Application deadline:

March 1st. Early applications are strongly encouraged.

Departmental web site:

physics.asu.edu

Application site:

physics.asu.edu/graduate/apply

Contact for Nuclear Physics:

Ricardo Alarcon
(480) 965-8549
ralarcon@asu.edu
physics.asu.edu/people/faculty

About ASU:

A comprehensive public metropolitan research university enrolling more than 70,000 undergraduate, graduate, and professional students on four campuses, ASU combines unique colleges, schools, departments, and research institutes into close-knit but diverse academic communities that are international in scope. ASU champions intellectual and cultural diversity, and welcomes students from all fifty states and more than one hundred nations across the globe.

ASU offers state-of-the-art scientific and technological research facilities, as well as other outstanding resources for study and research, including libraries and museums with important collections, and studios and performing arts spaces. ASU has been moving at an accelerated pace to establish itself as one of the leading centers for cutting-edge interdisciplinary research in selected areas, both fundamental and applied.

Graduate Studies in Physics at ASU:

- Award-winning faculty committed to excellence in scholarship and teaching.
- Modern curriculum bridging physics with astronomy, cosmology, engineering, chemistry, materials, and the life sciences.
- Growing programs in particle-astronomy, nuclear physics, and cosmology.
- Forefront research centers include the Center for Biological Physics, the Beyond Center for Fundamental Concepts in Science (beyond.asu.edu), the Cosmology Initiative, and the Origins Initiative (origins.asu.edu)

Nuclear Physics and Particle Astrophysics at ASU:



ASU faculty members are vigorously exploring the following areas (E=Experiment, T=Theory):

- Strong Interaction Physics [E,T]
- The Structure of Hadrons [E,T]
- Physics beyond the Standard Model [E,T]
- Tests of Fundamental Symmetries [E,T]
- Neutrinos: Properties and Astrophysical Implications [T]
- Cosmological Structure [T]

About Phoenix, Arizona:



Phoenix (the fifth largest city in the United States) and the surrounding area provides ASU students with cultural events, internships, shopping, entertainment and sporting events making ASU an ideal for a university setting in midst of a dynamic and emerging world city. In addition, Arizona is a great state for exploration. Miles of trails for hiking, biking and horseback riding are within minutes of Phoenix. The Grand Canyon, one of the natural wonders of the world, is less than 5 hours from any ASU campus.

Graduate Studies in Nuclear Physics at the
University of California, Los Angeles



Nuclear Physics Faculty/Staff:

| | |
|-----------------------|---|
| Experimental Faculty: | 1 |
| Experimental Staff: | 3 |
| Postdoctoral Fellows: | 2 |
| Graduate Students: | 8 |

Departmental web site:

<http://home.physics.ucla.edu>

Physics Graduate Programs:

<http://www.gdnet.ucla.edu/gasaa/pgmrq/physics2.asp>

Application information:

<http://www.pa.ucla.edu/content/graduate/admissions>

<http://www.gdnet.ucla.edu/gasaa/admissions/admisinfo.html>

Application Deadline:

December 15

Email apply@physics.ucla.edu for any question about applying to Physics and Astronomy graduate programs.

Contact in Nuclear Physics:

Huan Zhong Huang (黄焕中)
huang@physics.ucla.edu

General Information:

UCLA is one of the best public research universities in the world. It is ranked sixth in the nation for total research funds and has a large and diverse student body including 13,000 graduate and professional students. The campus is located only 5 miles from the Pacific Ocean and has close ties to the surrounding entertainment industry.

The UCLA Nuclear Physics Group has a broad physics program. It is a founding member of the STAR and sPHENIX collaborations at Brookhaven National Laboratory where graduate students in the group are studying properties of the Quark-Gluon Plasma and the spin composition of the proton. The group is also active in neutrino experiments including CUORE in Italy and is looking to recruit students for these efforts.

Nuclear Physics Research Areas:

Relativistic heavy ion collisions and QCD phases

Spin physics

Neutrino and Astroparticle physics

Other Research Areas in the Department:

Accelerator Physics

Atomic, Molecular, and Optical Physics (AMO)

Biophysics and Neuro-Physics

Condensed Matter Physics (CMP)

Experimental Elementary Particle Physics (EPPP)

Plasma Physics (PP)

Theoretical Elementary Particles (TEP)

Astronomy & Astrophysics (ASTRO)

University of California, Los Angeles

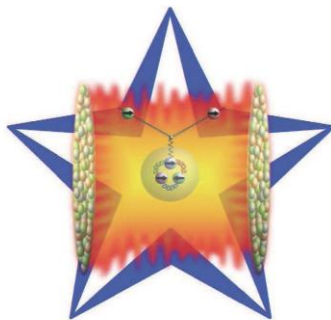
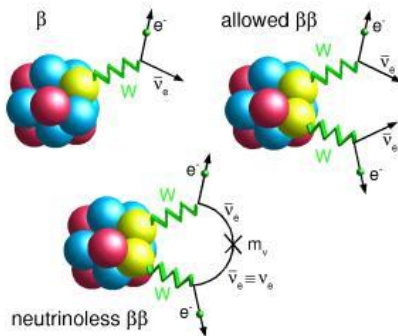
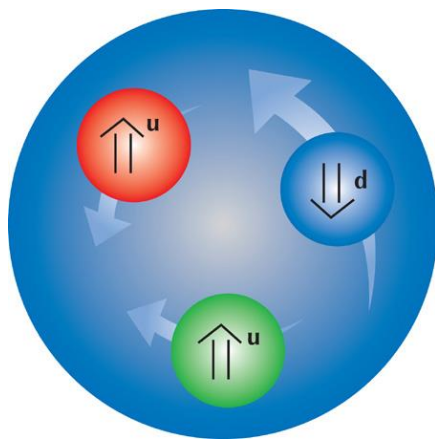
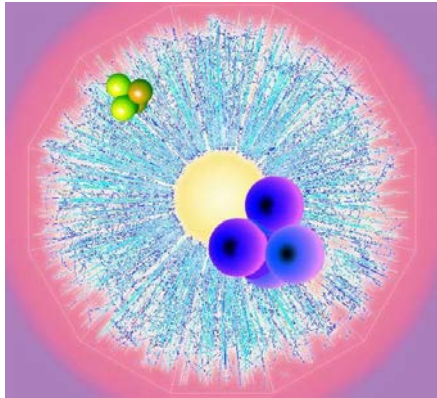

UCLA Relativistic Heavy-Ion
and Neutrino Physics Group

QCD Matter and QCD Phase Diagram:

Our experimental heavy ion program at the STAR experiment is to produce the Quark-Gluon Plasma (QGP) and to investigate its properties at high temperature and energy densities in heavy ion collisions. Our experimental measurements center on strange and heavy quark probes of QCD matter in terms of nuclear modification factors and azimuthal angular anisotropy of particle production in nucleus-nucleus collisions at RHIC. We also search for exotic particles and phenomena in heavy ion collisions. We have recently joined the sPHENIX collaboration, a new experiment designed to study jets and Upsilon production with unprecedented precision at RHIC. sPHENIX is expected to run in early 2020's.

The Spin Composition of the Proton:

Our intermediate energy physics program aims at measuring the gluon spin contribution to the proton spin and exploring the transversity function of the proton and quark/gluon orbital angular momentum distributions. Our experiment focuses on measurements of spin asymmetries of jets and leading particles in polarized p+p collisions at RHIC using the STAR detector at Brookhaven National Laboratory.

Neutrino Properties:

Our neutrino group participated in the Daya Bay experiment in China to measure the θ_{13} mixing angle using reactor neutrinos. The current focus of the neutrino physics group is to address the question of whether neutrino is its own antiparticle, so called a Majorana particle. This question is best answered by searching for neutrinoless double beta decay, a nuclear process which has never been observed. The group is involved in the CUORE experiment located in the Laboratori Nazionali del Gran Sasso in Italy. There are also R&D efforts towards the next generation of neutrinoless double beta decay experiment for the future.

Graduate Studies in Nuclear Physics at University of California, Davis



Nuclear Physics Group:

| | |
|----------------------|----|
| Experimental Faculty | 5 |
| Theoretical Faculty | 1 |
| Postdoctoral Fellows | 5 |
| Graduate Students | 18 |
| Female Members | 6 |

Department Ranking:

US News and World Report #26

Application Deadline:

For priority consideration Jan 2nd
Final deadline May 31st

Department Website:

<http://www.physics.ucdavis.edu>

Application Website:

http://gradstudies.ucdavis.edu/prospective/admissions_application.html

Graduate Program Coordinator:

Angela Sharma
(530) 752-1501
sharma@physics.ucdavis.edu

Contact in Nuclear Physics:

Daniel Cebra
(530) 752-4592
cebra@nuclear.ucdavis.edu
<http://nuclear.ucdavis.edu>

Nuclear Physics Research Area:

Relativistic Heavy Ions
Neutrino Physics
Applied Nuclear Physics

General Information:

UC Davis is a public research university and is one of the ten campuses in the University of California system. The school was originally established in 1905 as the University Farm, making Davis the second oldest campus in the UC system. Davis is a land-grant school with 5300 acres of land, making it the largest of the UC system schools. The school has a total enrollment of 33,300; of these 7,540 are graduate and professional students.

In the past decade or so, the physics department has seen marked growth. The faculty have increased from 25 to 44, and the graduate population has increased from 75 to 180. Currently the graduate program has 23% international students and 18% women. The department has large groups in theoretical and experimental condensed matter, theoretical and experimental particle physics, and theoretical and observational cosmology. There are smaller, focused groups in nuclear physics, computational physics, biophysics, and physics education.

Davis is in close enough proximity to two major national laboratories: Lawrence Berkeley National Laboratory and Lawrence Livermore National Laboratory. There are opportunities for students to either use the facilities available there or to pursue their dissertation research under joint supervision of a laboratory scientist and a Davis faculty member.

University of California, Davis



Relativistic Heavy Ion Physics:

The Solenoidal Tracker at RHIC (STAR) is one of the major experiments at BNL's Relativistic Heavy Ion Collider (RHIC). The Davis group has been pursuing high p_t studies of heavy quark production and lower p_t studies of global observables. The Compact Muon Solenoid (CMS) is one of the major experiments at CERN's Large Hadron Collider (LHC). Although CMS was designed as an elementary particle physics experiment, it has capabilities which make it excellent for the heavy ions beams, which are available for one month of each year. The LHC is providing the highest energy ion beams. The 4π muon coverage of CMS makes it an ideal experiment for the study of J/Ψ and Y .

Neutrino Physics:

UCD has an active research program in experimental neutrino physics and dark matter. The group is taking data at the reactor based Double Chooz neutrino oscillation experiment and the Large Underground Xenon (LUX) dark matter experiment. Future efforts will be focused on the Long Baseline Neutrino Experiment, an experiment designed to look for neutrino CP violation, measure the mass ordering, detect supernovae, and make precision measurements of neutrino oscillation parameters. In the dark matter sector, a new detector called LZ has been proposed.

Applied Nuclear Physics:

UCD is a member of the Nuclear Science and Security Consortium (NSSC). Davis hosts a summer school covering reactor physics, non-proliferation policy, and imaging techniques; including hands-on Neutron Activation Analysis using the McClellan Nuclear Reactor Center

About Davis, California:

Davis is a small college town (population about 60,000), located in Yolo County in California's Central Valley, about 75 miles inland from San Francisco and 15 miles from the state capital of Sacramento. The Central Valley is the major agricultural region of the state of California. The valley has a Mediterranean climate with hot dry summers and a cool rainy season. The topography of Davis is flat, which has helped it become an extremely bicycle friendly community. From Davis, one has easy access to hiking and skiing in the Sierra Nevada mountains and to the rugged coastline of the Pacific Ocean.



Graduate Studies in Nuclear Physics at **Central Michigan University**

Nuclear People:

Experimental Faculty: 4
Theoretical Faculty: 1
Postdoctoral Researchers: 2
Graduate Students: 10

Application deadline:

May 1st application deadline, but February 1st for full consideration for a teaching or research assistantship.

General university, department, and admissions information:

<http://grad.cmich.edu>
(989) 774-GRAD

Departmental web site:

<http://cmich.edu/colleges/cst/physics/>

Application site:

<http://grad.cmich.edu>

Contact:

Christopher Tycner
(989) 774-3321
c.tycner@cmich.edu

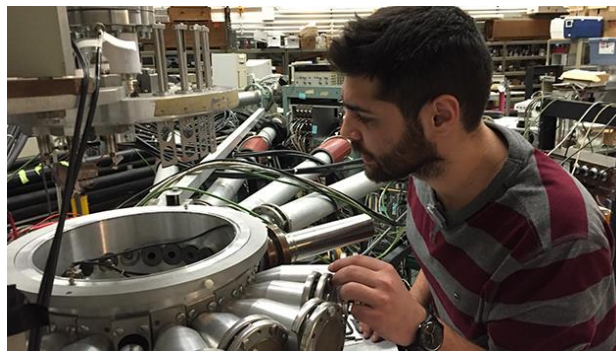
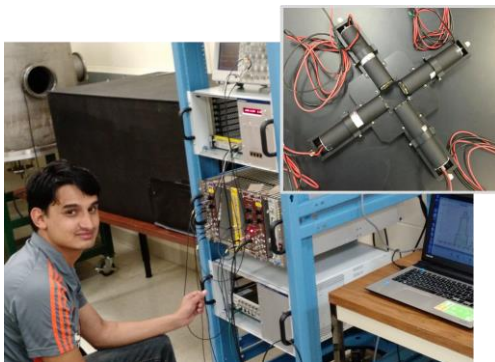

General Info:

Central Michigan University has a distinctive role among the nation's colleges and universities in the way we successfully blend faculty teaching and student learning.

CMU is a comprehensive higher education institution that is classified by the Carnegie Foundation as a Doctoral Research University. Graduate students in physics have the opportunity to obtain a Master's degree in physics or astronomy, and a Ph. D. in the Science of Advanced Materials.

Most of CMU's 27,000+ students are on the university's main campus, where you'll find intellect, energy and natural splendor. Walk, run or bike to class. You're no more than 10 to 15 minutes from any destination, on a campus as great for sightseeing and connecting with friends as it is for academic success. With 22 residence halls, apartments and the newly built graduate student housing, "Chips" sleep well. You'll also find on-campus perks such as coffee shops, carry-out cuisine, gleaming fitness facilities and diverse programming.

Nuclear physics research areas:

Experimental physics with radioactive ion beams
High-precision mass measurements
Penning trap mass spectrometry
Beta-decay studies
Medical physics
Nuclear astrophysics
Nuclear structure and reactions

Experimental Nuclear Physics:

Since 2012 the Physics department has hired three additional experimental nuclear physics faculty members: George Perdikakis, Matt Redshaw and Alfredo Estrade. They have joined professor Joe Finck to lead and participate in experiments at the National Superconducting Cyclotron Lab (NSCL) utilizing the S800 spectrometer, the LEBIT Penning trap mass spectrometer, and the MoNA LISA neutron detectors. By studying the short-lived rare isotopes that are produced at the NSCL, the researchers will learn about the structure of the nucleus, the nature of the forces that hold it together, and the astrophysical processes that produce the heavy elements we find in nature.

The CMU nuclear physics faculty also perform experiments at facilities all over the U.S. and the world, including Argonne National Lab, the University of Notre Dame, TRIUMF National Lab in Canada, and RIKEN in Japan. Our group of experimentalists are actively involved in experimental developments for the Facility for Rare Isotope Beams, a new \$600 million national user facility for nuclear science that will be the world's most powerful rare isotope beam facility and is currently under construction at Michigan State University. For example, graduate students at CMU are developing prototypes for timing detectors for mass measurement experiments with the future High Rigidity Spectrometer at FRIB.

Ultra-high-precision mass spectrometry:

At CMU Matt Redshaw is developing a Penning trap for ultra-high-precision mass measurements using single ions. A novel double-Penning trap, housed inside a 12 T superconducting magnet, is being built for simultaneous mass comparisons between two ion species. The Penning trap will be used for measurements with stable and long-lived isotopes produced from a variety of ion sources, including a laser ablation source. The research program will include precise atomic mass measurements for atomic and nuclear physics, beta-decay and electron capture Q-value measurements for isotopes used in direct neutrino mass determination experiments, and neutron separation energy measurements for a test of $E=mc^2$.

Nuclear Theory and Medical Physics:

Nuclear theory and medical physics research is led by Mihai Horoi. Professor Horoi's main research interests are theoretical nuclear structure, nuclear level densities for nuclear reactions and nuclear astrophysics, and the theoretical aspects of the double-beta decay process. To accomplish his research goals he is using massively parallel computers available at the regional and national supercomputer centers.

Dr. Horoi has also recently advised several MS theses aiming at different physics aspects of modern medical techniques, such as proton/carbon radiation therapy, positron emission tomography (PET), and computer aided tomography (CAT) for medical imaging.

JINA-CEE:

Faculty, and graduate as well as undergraduate students of the department of Physics are participating members in the Joint Institute for Nuclear Astrophysics - Center for the Evolution of the Elements (JINA-CEE), a National Science Foundation Frontiers Research Centre that supports interdisciplinary research connections between experimental and theoretical nuclear physicists, computational physicists, theoretical astrophysicists, and astronomers. Besides participating in JINA-CEE meetings and experimental collaborations, CMU students are working on computational projects to understand the role of nuclear reactions in a number of nucleosynthesis processes.

About Mt. Pleasant:

There aren't many places like the city of Mount Pleasant. It's a safe, relaxing environment that offers a small-town feel but within close proximity to Lansing, Grand Rapids, Detroit and Chicago. Enjoy Mount Pleasant's 15 area parks and discover all that the Chippewa River has to offer. Four full seasons can be enjoyed, including warm summers at the Lake Michigan beaches and snowy winters on the ski hills of northern lower Michigan.

Graduate Studies in Nuclear Physics at the University of Colorado at Boulder



Nuclear physics faculty

| | |
|----------------------|---|
| Experimental faculty | 4 |
| Theoretical faculty | 1 |
| Graduate students | 6 |

Departmental web site

www.colorado.edu/physics/

Graduate application site

www.colorado.edu/physics/admissions/graduate-application-info-and-deadlines

Application deadline

December 15th

Contact for Nuclear Physics

Professor Dennis Perepelitsa
(303) 735-5493
dvp@colorado.edu



About the University of Colorado at Boulder

As the flagship university of the state of Colorado, CU-Boulder is a dynamic community of scholars and learners situated on one of the most spectacular college campuses in the country. The University of Colorado at Boulder is a Tier 1 research institution that received more than \$436 million in sponsored research awards for the 2015-2016 fiscal year, placing us in the 9th percentile nationally.

The university offers 70+ majors at the bachelor's level and more than 100 graduate and professional programs. The faculty includes five Nobel Laureates, eight McArthur Fellows, 19 Rhodes Scholars, and two National Professors of the Year, among many others. Its programs in aerospace engineering, ceramics, environmental law, geology, physical chemistry, quantum and atomic/molecular/optical physics are ranked in the top 10 nationally.

The main campus is on 600 acres in heart of beautiful Boulder, Colorado.

Nuclear physics research areas

Relativistic Heavy Ions
Quark-gluon Structure of Nucleons
Nuclear reactions

Major research areas in department

Atomic and Molecular Physics
Condensed Matter Physics
Elementary Particle Physics
Geophysics
Plasma Physics

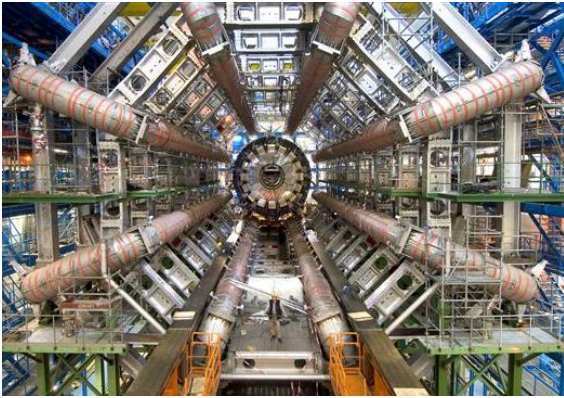

ATLAS Experiment at the Large Hadron Collider

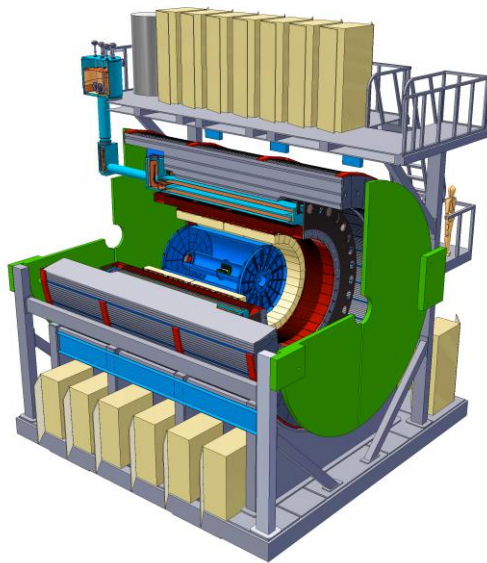

Proposed “sPHENIX” Experiment at the Relativistic Heavy Ion Collider



E906 Experiment at Femi National Laboratory

Nuclear Physics Research at CU-Boulder

The nuclear physics group at the University of Colorado consists of four experimentalists and one theorist.

Professor Dennis Perepelitsa and Professor Jamie Nagle have a strong involvement in relativistic heavy ion physics, with a current focus on the ATLAS experiment at Large Hadron Collider in Geneva, Switzerland, and on the proposed sPHENIX detector at the Relativistic Heavy Ion Collider in Long Island, New York. The scientific goals of this research are to understand the phase transformation of nuclear matter to a quark-gluon plasma at very high temperatures – the same plasma which existed a few microseconds after the Universe started with the Big Bang. The CU-Boulder group is involved in physics analysis, high speed digital electronics, and detector development.

Professor Ed Kinney’s research is focused on understanding the quark-gluon structure of the nucleon. Even such a basic aspect as the proton spin is poorly understood, with quark spin and gluon contributions playing only a surprisingly minor role. Present experimental studies are based at the Drell-Yan experiment (E906) at Fermilab, to study the unmeasured antiquark composition of the nucleon at high internal momentum. Future studies at the newly upgraded Jefferson Lab electron accelerator will probe the momentum distribution of quarks as they are struck and ejected from the nucleon.

Professor Jerry Peterson works on the applications of nuclear reactions for spallation sources and nuclear astrophysics.

The Theory Program is led by Professor Paul Romatschke and the effort focuses on strong coupling techniques for modeling high energy nuclear collisions, such as relativistic fluid dynamics and gauge/gravity duality.



About Boulder, Colorado

The University of Colorado is located in Boulder, which is approximately 40 minutes away from Denver, Colorado. Boulder is consistently rated as one of the “Happiest”, “Brainiest” and “Healthiest” cities in which to live in the United States of America.

Graduate Studies in Subatomic Physics at the Colorado School of Mines

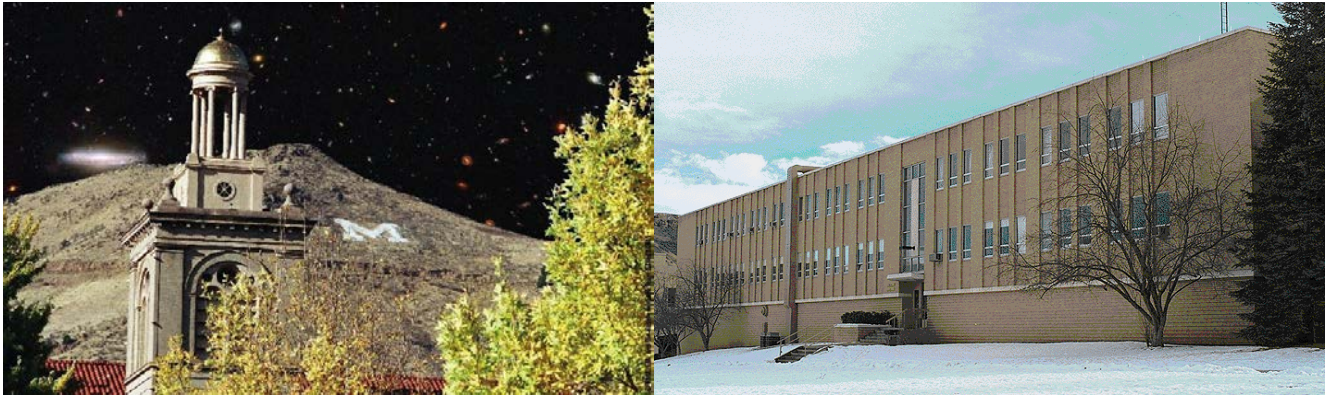

Nuclear People:

Experimental Faculty:..... 4
Postdoctoral Fellows:..... 2
Graduate Students:.....about 18

Median Time to PhD:

4.5 to 5.5 years

Application deadline:

Middle of January

General university, department, and admissions information:

http://www.mines.edu/Graduate_PR

Departmental web site:

<http://physics.mines.edu>

Contacts:

Uwe Greife (Nuclear / Nuclear Eng.)
(303) 273-3618
ugreife@mines.edu

Kyle Leach (Nuclear)
(303) 273-3044
kleach@mines.edu

Fred Sarazin (Nuclear / Astroparticle)
(303) 273-3283
fsarazin@mines.edu

Lawrence Wiencke (Astroparticle)
(303) 384-2234
lwiencke@mines.edu

General Info:

Located in the scenic foothills of the Colorado Rockies, the Colorado School of Mines has distinguished itself through research and educational programs in the areas of resources, environment, materials, and energy. There are about 3500 undergraduates and 900 graduate students enrolled at CSM.

The physics department hosts cutting-edge research facilities and innovative research centers with approximately 25 regular and research faculty, over 220 undergraduate majors and 50 graduate students.

The subatomic physics group at CSM is a well-established group in the field of low-energy nuclear structure, astrophysics and fundamental symmetries using radioactive ion beams. Additionally, we pursue experiments with neutron beams applicable to nuclear energy topics.

More recently, astroparticle physics was added to our focus areas through the study of the highest energy cosmic rays with the Pierre Auger observatory. We are also involved in a project aiming at detecting those cosmic-rays from space.

Subatomic physics research areas:

Astroparticle physics
Fundamental symmetries
Nuclear astrophysics
Nuclear fission
Nuclear structure

Other broad research areas in department:

Condensed matter physics, education research, energy physics, theoretical physics, ultra-fast optics

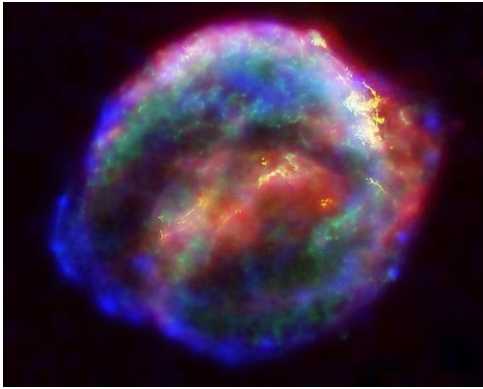

Experimental Low Energy Nuclear Physics:

The study of unstable nuclei with large proton or neutron imbalances has revealed many new behaviors not predicted by the shell model, the theory so successful in describing the properties of the stable nuclei, thereby questioning our fundamental understanding of the nucleus. Answering such questions is not only critical to comprehend the nucleus as a many-body quantum system, it is also necessary to get a grip on the multitude of astrophysical processes in the Universe. Nuclear physics is also a fertile ground to test fundamental symmetries and the Standard model. Our group pursues experiments at NSCL/FRIB (Michigan State), ATLAS (Argonne) and ISAC/TRIUMF (Vancouver).



Astroparticle Physics:

The goal of the Pierre Auger observatory is to study the highest energy cosmic rays, believed to be mostly charged particles. Their nature and origin however remains largely unknown. Studying these particles also allows us to probe hadronic interaction mechanisms well beyond the energy of the largest man-made accelerators. The Auger group at CSM studies data from the southern site in Argentina and has responsibility for critical instruments. It is also working on cross-calibration with another experiment in Utah. The group is also involved in a project aiming at measuring cosmic-ray showers from space.

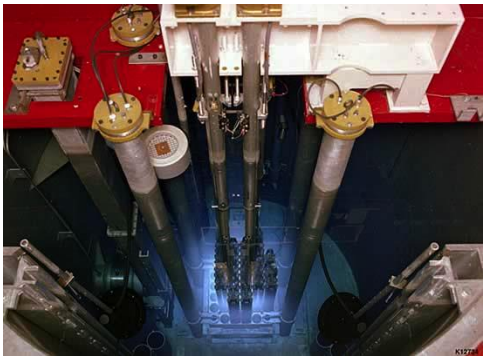

Nuclear Engineering:

The Colorado School of Mines started in 2007 with an interdisciplinary program entitled “Nuclear Science and Engineering”. As a member of this effort, the subatomic physics group is involved in research related to nuclear and homeland security and supports the interdisciplinary graduate program in nuclear engineering (MSc and PhD). We are developing detectors for precision fission cross section measurements at the Los Alamos Neutron Science Center (LANSCE) as well as new materials for neutron and gamma detection.



About Golden:

Colorado School of Mines is located in Golden, about 15 miles west of Denver along the foothills of the Colorado Rockies. The area offers many possibilities for outdoor summer and winter activities, while having also easy access to the city life of nearby Denver. Golden is the site of North America’s largest single site brewery (Coors), but also offers just off campus the possibility of relaxing with brew from smaller batches.

Graduate Studies in Nuclear Physics and Astronomy at:

University of Connecticut



Physics People

Regular Faculty: 33

Research Faculty: 12

Graduate Students: 82

Undergraduate Students: 150

Ph. D. Program:

<http://physics.uconn.edu/graduate/>

Application deadline:

Applicants are advised to apply by **January 15** for admission in the following Fall semester.

Departmental web site:

<http://physics.uconn.edu/>

Application site:

<http://physics.uconn.edu/graduate/applications/>

Contact for Nuclear Physics:

Prof. [Richard T. Jones](#)

+1 860 486 3512

richard.t.jones@uconn.edu

Physics Graduate Affairs:

Prof. [Niloy Dutta](#)

+1.860.486.3481

niloy.dutta@uconn.edu

About the Physics Department

The Physics Department offers a wide range of graduate and undergraduate courses together with many research opportunities in numerous fields including atomic and molecular physics, quantum optics, laser physics, nuclear physics, particle and astro-particle physics, astronomy, astrophysics, cosmology, quantum field theory, condensed matter physics, polymer physics, geophysics, mathematical and computational physics.

About the University

UConn is the #1 public university in New England, and among the top 20 public universities in the nation. Founded in 1881, UConn has today 23,500 undergraduates and 8,000 graduate students. An unprecedented \$3 billion investment in UConn's infrastructure has made campus life more enjoyable than ever. The Next Generation Connecticut initiative is under way, an ambitious investment of the State of Connecticut that will allow UConn to expand, construct new research facilities, hire new faculty and admit 3,000 more students especially in STEM fields, see <http://nextgenct.uconn.edu/>. UConn's website is <http://www.uconn.edu/>, and the latest news can be found on "UConn Today:" <http://www.today.uconn.edu/>. For more information we invite to tour UConn's Graduate School website: <http://grad.uconn.edu/prospective-students/>.

About Storrs

The Physics Department is located in Storrs, CT, in scenic New England, surrounded by intact nature, about half way between Boston and New York. Hartford is about 1/2 h away. About 12,000 students live on Campus or in Storrs, and enjoy the rich cultural and recreational opportunities. Storrs has a unique community that is stimulated by numerous outreach activities which provide valuable engagement opportunities for students.

Nuclear Physics at UConn

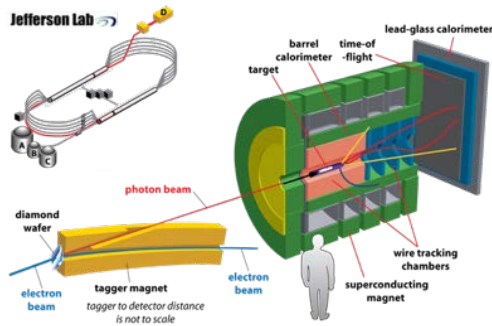

Fig. 1. GlueX experiment at Jefferson Lab.

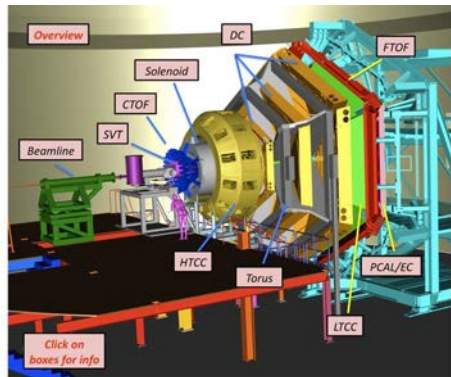

Fig. 2. CLAS experiment at Jefferson Lab.

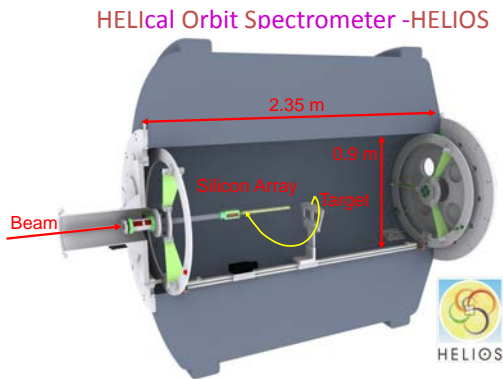

Fig. 3. Helical Orbit Spectrometer (HELIOS) at Argonne National Laboratory.



Fig. 4. Studies of galactic structure at UConn.

Faculty: [R. Jones](#), [K. Joo](#), [A. Kovner](#), [A. Puckett](#), [P. Schweitzer](#), [A. Wuosmaa](#) (nuclear physics), [C. Battersby](#), [J. Trump](#), [K. Whitaker](#) (astro)

Exotic Mesons.

Following the upgrade of Jefferson Lab (JLab) to a beam energy of 12 GeV, the GlueX experiment, Fig. 1, will provide critical data on exotic hybrid mesons, whose quantum numbers require explicit gluons in the wave function, in addition to the quark-antiquark pair that makes up ordinary mesons. The experiment will shed light on the confinement mechanism of quarks and gluons in quantum chromodynamics (QCD). The group of [Richard Jones](#) is actively involved in the preparation of this experiment.

Spin Structure of Nucleon.

Imaging of quarks inside nucleons is in the focus of the CLAS experiment, Fig. 2. The extensive research program of [Kyungseon Joo](#)'s group spans from studies of generalized and transverse momentum dependent distribution functions, over hadron formation, to the nucleon resonance N^* physics. The group leads the design and construction of major detector components.

3D Imaging of Nucleon.

The not yet well-explored 3D structure is also in the focus of [Andrew Puckett](#)'s group involved in experiments planned in JLab's Halls A and B that will address orbital angular motion of quarks, or the spatial distribution of charge at small distance scales. The group plays a lead role in the development of Cherenkov counters for efficient identification of charged particles, and data analysis.

Nuclear structure beyond the valley of stability.

The group of [Alan Wuosmaa](#) probes the structure of neutron-rich nuclei far beyond the valley of stability through rare-isotope beam experiments at the Argonne National Laboratory, Fig. 3. Research in the group includes also studies of clustering phenomena in light nuclei, investigations of astrophysical nucleosynthesis through the interactions of exotic nuclear species, and development of advanced instrumentation for nuclear physics.

Theory of Hadrons and QCD.

The study of the internal structure of hadrons and QCD phenomena in high-energy processes are in the focus of the groups of [Alex Kovner](#) and [Peter Schweitzer](#).

Astronomy and Astrophysics.

The groups of [Cara Battersby](#), [Jonathan Trump](#), and [Kate Whitaker](#) perform observational studies of galactic structure, galaxy formation and evolution, see Fig. 4, super-massive black holes, star formation, and the early Universe.

Graduate Studies in Nuclear Physics at Creighton University



Nuclear Physics Faculty/Staff:

| | |
|---------------------------|---|
| Experimental Faculty: | 4 |
| Theoretical Faculty: | 1 |
| Postdoctoral Researchers: | 2 |
| Other Research Staff: | 1 |
| Graduate Students: | 4 |

Rankings :

#1 Midwest Masters Level
University, U.S. News & World
Report

Application deadline:

No firm deadline for admission.
April 15 to be considered for
fellowships.

General university, department, and admissions information:

www.creighton.edu

Departmental web site:

physicsweb.creighton.edu

Application site:

www.creighton.edu/gradschool

Contact:

Michael Cherney
(402) 280-3039
mcherney@creighton.edu

General Info:

Founded in 1878, Creighton is a Jesuit university with 9 schools and colleges. The Physics Department offers a Masters degree program in Physics and Physics MS / Teaching Certification Program. Undergraduate degrees are offered in Physics, Energy Science and Applied Physical Analysis. In addition to the normal teaching assistantships and research assistantships, a special fellowship is available for women graduate students in Physics. The on-campus enrollment at Creighton University for the 2013 fall semester was approximately 7,700, including 3,500 graduate and professional students. The Creighton campus is located near downtown Omaha and the university is a member of the Big East Conference and hosts the College World Series at its home field, TD Ameritrade Park.

Nuclear physics research areas:

Ultra-relativistic heavy ion physics
Experiment controls systems
Nuclear astrophysics
Nuclear interactions with inner shell electrons

Other broad research areas in department:

Astronomy and astrophysics
Biophysics
Condensed matter physics
Elementary particle physics
Laser cooling and trapping
Nanofabrication
Solar technology and sustainable design

Creighton University



Janet Seger



Michael Cherney



Thomas McShane



Gintaras Duda

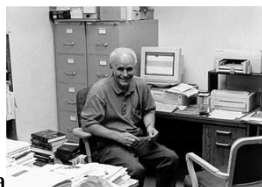

Sam Cipolla

Ultra-relativistic Heavy Ion Collisions:

The group studies primarily ultra-peripheral nuclear collisions using the STAR detector at Brookhaven National Laboratory and the ALICE detector at CERN. The group is also responsible for the hardware controls system for the entire STAR experiment and the electromagnetic calorimeter of the ALICE detector. Graduate students have the opportunity to work at both Brookhaven or CERN. Students may continue their course work while stationed either in Geneva or on Long Island as graduate courses are taught in classrooms that are equipped for remote instruction. Student have the option of completing either a physics analysis or a hardware thesis. The group has the longest continuously renewed grant at the university.

Website: <http://physicsweb.creighton.edu/rhic/>

Theoretical Nuclear Astrophysics:

Work at Creighton in theoretical astro-nuclear physics, an interdisciplinary field which attempts to solve problems in astronomy using particle and nuclear physics solutions, focuses on the characterization and detection of dark matter, in particular through direct detection where dark matter particles scatter from nuclei and the physics of massive neutrinos.

Low Energy Nuclear Physics:

Low energy nuclear physics and high energy atomic physics studies at Creighton are carried out in a dedicated facility using radioactive sources.

About Omaha:

Creighton University is located on a 130-acre campus in Omaha, NE. The city proper has a population of approximately 420,000 with 880,000 people in the metropolitan area. The university is in walking distance of the Missouri River with its hiking and biking trails and downtown Omaha which serves as the home to Berkshire Hathaway, the Union Pacific Railroad, Mutual of Omaha and ConAgra, as well as a vibrant arts and music community. Omaha is served by six major airlines, Amtrak and two interstate highways. Kiplinger magazine picked Omaha as the #1 best value city in the US in 2011.

Graduate Studies in Nuclear Physics at Duke University, Durham, NC

Duke
UNIVERSITY

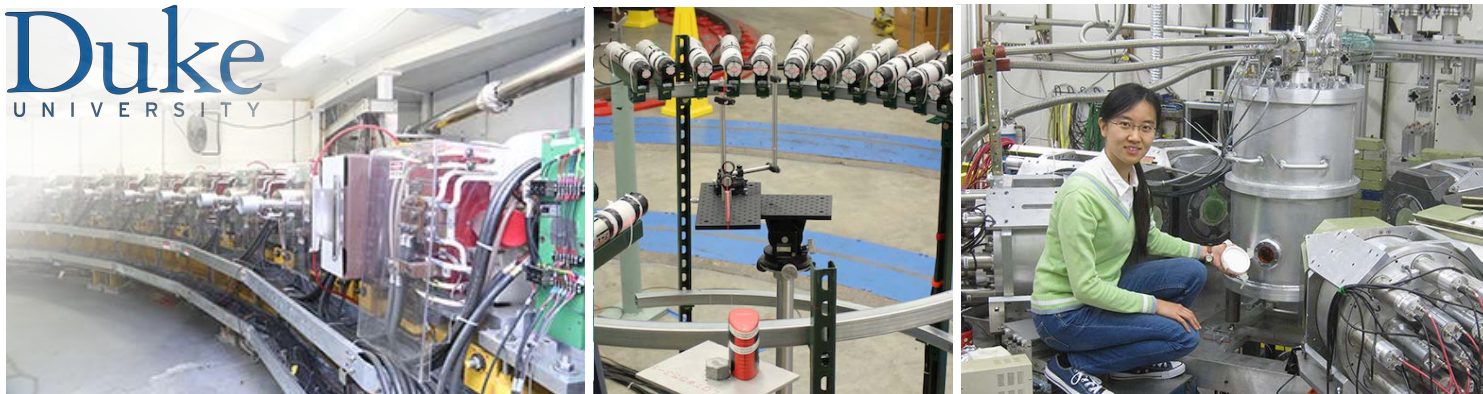

Nuclear People

| | |
|----------------------|----|
| Experimental Faculty | 6 |
| Theoretical Faculty | 5 |
| Graduate Students | 28 |

Web

www.phy.duke.edu
www.tunl.duke.edu
www.duke.edu

Application:

Deadline - December 15th

<http://www.phy.duke.edu/graduate/>

Contacts

Duke Physics

Stephen Teitsworth
dgs@phy.duke.edu
(919) 660 2560



TUNL

Art Champagne, Director
aec@tunl.duke.edu
(919) 660 2600

General Information

The Duke graduate program in physics prepares students for careers in research and education, technology industries, and other professions in which reductionistic problem solving skills are important. The graduate education experience cultivates students' command of physics concepts, problem analysis methods and science communication skills through course work and research. Students carry out research on topics at the frontier of the field using state-of-the-art research facilities and instruments in collaboration with world experts.

Graduate students at Duke have opportunities to conduct world-class experimental and theoretical research in nuclear physics. The experimental program is led by groups at the Triangle Universities Nuclear Laboratory (TUNL), which is a Department of Energy Center of Excellence for nuclear physics. The research includes experiments in electroweak interactions, neutrino physics, dark-matter particle searches, hadron structure and nuclear astrophysics. Experiments are carried out at local accelerator facilities, such as the High Intensity Gamma-Ray Source (HIGS), national accelerator laboratories, such as the Jefferson Laboratory and the Spallation Neutron Source at Oak Ridge National Laboratory, and deep underground research facilities around the world.

The research in theoretical nuclear physics include nuclear matter at extreme energy density with emphasis on studying the properties of quark-gluon plasma, quantum chromodynamics on the lattice, and effective field theories of the nuclear interaction and nuclear reactions.

Nuclear Physics Research Areas

Electroweak interactions and fundamental symmetries
Hadron structure and Few-Nucleon Physics
Neutrino physics
Nuclear astrophysics and nuclear structure
Relativistic heavy-ion collisions and quark-gluon plasma
Accelerator physics for nuclear physics research
Applications of nuclear physics in nuclear security and plant biology



About the Research Triangle of North Carolina

The area around Raleigh, Durham and Chapel Hill is called the Research Triangle Area because of the three major research universities and the Research Triangle Park. The Research Triangle Park (RTP) is a 7,000 acre development that is home to more than 170 companies. Duke is located a 2.5-hour drive from the Atlantic Beaches, three hours from the Appalachian Mountains, and five hours from the Washington, DC area.



Grandfather Mountain



Duke University Chapel

Experimental Nuclear Physics at TUNL

Nuclear Astrophysics

The central themes in nuclear astrophysics research at TUNL are the structure, evolution and nucleosynthesis of evolved stars that give rise to supernova explosions, the nuclear reactions that regulate energy production during the period of the carbon-nitrogen burning cycle of low- to medium-mass stars, element abundances in globular cluster stars, and nuclear reactions that power classical novae. Many of our experiments are performed at local facilities, for example, the Laboratory for Experimental Nuclear Astrophysics (LENA) and HIGS.

Neutrino Physics and Fundamental Symmetries

The focus in these areas are on experiments aimed to answer several fundamental questions: Are neutrinos Dirac or Majorana particles? What are the absolute masses of neutrinos and what can we learn from the hierarchy of particle masses? Do the properties of neutrinos and the size of the neutron electric dipole moment (nEDM) offer an explanation for the observed matter to antimatter asymmetry? Can neutrino interactions with matter reveal undiscovered forces? Experiments include searches for neutrinoless double beta decay of nuclei, measurements of coherent neutrino scattering on nuclei, and a search for the nEDM.

Medium Energy Physics & Structure of Hadrons

A major goal of this research is to understand the structure of hadrons in terms of quark and gluon degrees of freedom of Quantum Chromodynamics (QCD). A significant part of this work is to measure three-dimensional images of the internal structure of the nucleons in momentum space, search for exotic states, and perform precise measurements of the charge radius of the proton. Also, this research includes testing predictions of Chiral Effective Field Theories (χ EFT) via high-precision polarization measurements of electromagnetic reactions on few-nucleon systems, such as Compton scattering on the proton, deuteron and He-3.

Theoretical Nuclear Physics at Duke

Relativistic Heavy-Ion Physics and Quark-Gluon Plasma

The focus of this program is on studying the properties of nuclear matter at extreme temperatures and densities, in particular the "Quark-Gluon Plasma". The QGP is a state of matter that existed in the Universe shortly after the Big Bang and that can be recreated in the lab via ultra-relativistic collisions of heavy nuclei. The Duke QCD group works on developing computational models for the dynamics of highly energetic heavy-ion collisions, and on connecting theoretical predictions of QGP properties to experimental measurements. This research involves the application of transport theory, statistical mechanics, heavy-ion phenomenology, as well as the fundamental laws of QCD.

Lattice and Effective Field Theory Studies of QCD

Researchers at Duke use lattice and Effective Field Theories (EFTs) to study processes in both nuclear and particle physics. Lattice field theory methods, coupled with Monte-Carlo algorithms, are essential to extracting hadron properties from first principles. EFTs are based on symmetries of the strong interaction and are used to make model-independent predictions of hadron properties and their interactions at low energies where perturbative QCD methods are not applicable. Examples include the use of EFTs to study the manifestations of the weak interaction in hadronic systems through parity violating observables, and the analysis of few-nucleon systems.

Graduate Studies in Nuclear Physics at Florida International University



Nuclear People:

Experimental Faculty: 5
Theoretical Faculty: 3
Graduate Students: 12

Ranking:

FIU ranks 1st in the U.S. for granting bachelor's degrees to minorities, and 1st for granting STEM degrees to minorities

Application deadline:

April 1st to be considered for fall admission. Review of applications for assistantships begins in January

General university, department, and admissions information:

GRE general exam required. B.S. or B.A. in physics or closely related field.

Departmental web site:

physics.fiu.edu

Application site:

gradschool.fiu.edu/admissions.shtml

Contact:

Dr. Brian Raue
(305) 348-3958
brian.raue@fiu.edu
physics.fiu.edu/graduate-program

General Info:

Florida International University, founded in 1969, is a public research university located in Miami, Florida. It is the 7th largest university in the country, awarding over 3,400 graduate and professional degrees annually. Through its 23 colleges and schools, FIU offers 191 different programs and 280 majors. FIU has an annual budget of over \$1 billion, and more than \$100 million in research expenditures annually.

The on-campus enrollment at Florida International University for the 2012 fall semester was approximately 50,000, including 14,000 graduate and professional students.

Nuclear physics research areas:

Short range correlations
Internal structure of hadrons
Hadron spectroscopy
Hypernuclei physics
Plasma physics

Other broad research areas in department:

Astronomy
Condensed matter physics and AMO
Biophysics and Neuroimaging
Experimental particle physics
Physics Education Research

Assistantships:

Financial aid is available in the form of Teaching or Research Assistantships that include a tuition waiver and a stipend (~\$24,000 per year).

Florida International University



Graduate students working in Jefferson Lab
Experimental Hall B

Research at Jefferson Lab:

The FIU experimental nuclear physics group is focused on studying the nature of QCD and the spectrum of hadrons through various experimental programs conducted at the Thomas Jefferson National Accelerator Facility (Jefferson Lab). The group is involved in experiments in all four halls at Jefferson Lab.

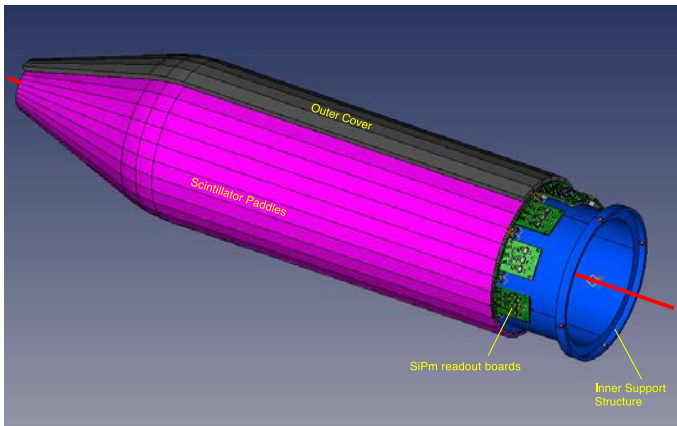

Schematic of GlueX start counter being built at FIU

Research at FIU:

Although the experiments are conducted at Jefferson Lab the construction of certain detectors, and offline data analysis are done on the FIU campus.



South Beach, Miami Beach, FL

About Miami:

Florida International University is located in Miami, just minutes away from the famous Miami Beach, and less than an hour away from the Everglades National Park. The Miami-Fort Lauderdale Metropolitan area is one of the most popular tourist destinations for people from all over the world.

Graduate Studies in Nuclear Physics at The George Washington University

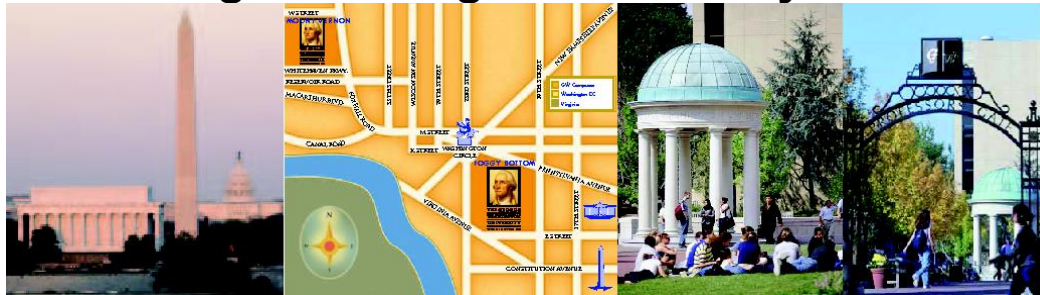

Nuclear People:

Experimental Faculty: 5
Theoretical Faculty: 8
Nuclear Phenomenology 2
Nuclear Astrophysics: 5
Graduate Students: 10
Female Faculty: 2
Female Graduate Students: 3

Application Deadline:

January 10 to be considered for a fellowship

Department Web Site:

<http://www.phys.gwu.edu/>

Application Web Site:

<http://www.gwu.edu/~gradinfo/>

Contact in Nuclear Physics:

Frank X. Lee
Physics Department
The George Washington University
725 21st Street, NW
Washington, DC 20052
Telephone: 202-994-6485 (office)
202-994-3001 (fax)
<http://home.gwu.edu/~fxlee>
Email: fxlee@gwu.edu

The George Washington University grew out of the desire of our country's first President to establish a national institution of higher learning. Following an act of Congress in 1821, GW opened its doors as Columbian College in the District of Columbia. In 1904, the name of the institution was changed to The George Washington University.

Today, GW is the premier urban research university in the nation's capital, with a total enrollment of more than 19,000 undergraduate and graduate students in nine schools. The University's commitment to excellence in teaching and research is exemplified by the recent decision to build a new multi-million dollar Science and Engineering Complex that is bound to set a new standard others can aspire to.

The University's Washington, DC, location—just four blocks from the White House and six blocks from the Kennedy Center for the Performing Arts on the Potomac River—offers a rich variety of cultural opportunities for the university community. The Smithsonian Institutions and the monuments of the National Mall are also within walking distance of the University, as is the nightlife of Georgetown and Adams Morgan.

Nuclear Physics Research Areas:

Experimental Nuclear Physics
Theoretical Nuclear Physics
Nuclear Phenomenology
Nuclear Astrophysics

Other Research Areas in the Department:

Experimental Biophysics
Theoretical Biophysics
Medical Physics
Observational Astrophysics

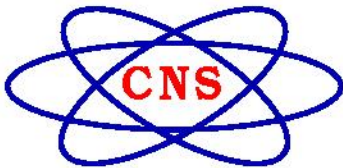
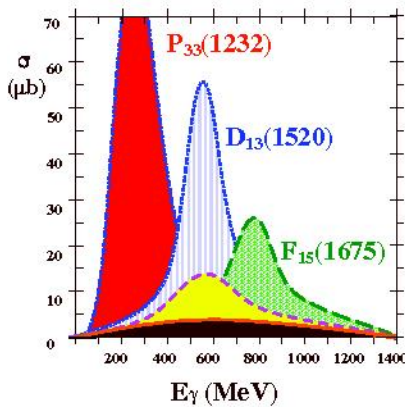

Center for Nuclear Studies
Data Analysis Center
<http://gwdac.phys.gwu.edu/>

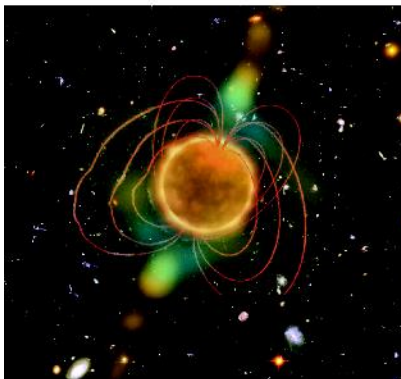

Experimental Nuclear Physics:

Experimental nuclear physics at GW focuses on understanding fundamental aspects of nuclear physics related to the basic building blocks of nature and how those building blocks interact with each other in nucleons and few-body nuclei. Most of our experiments use photon or electron beams and take advantage of the fact that the interaction initiating the reactions, the electromagnetic force, is well understood. This allows us to focus on the less well understood nuclear (strong) force. While Quantum Chromodynamics (QCD) and the Standard Model are the best descriptions physics has for our subatomic observations, there are many unanswered questions and we are looking for the answers.

Theoretical Nuclear Physics:

Theoretical nuclear physics at GW aims to understand the structure and interactions of photons, hadrons, and nuclei at low and intermediate energy scales. To this end, we employ a variety of approaches and methods. We do calculations in Lattice QCD which simulate the low-energy limit of QCD on massively-parallel super computers. In the Effective Field- Theory approach, we systematically explore the low-energy limit of QCD in terms of explicit hadronic degrees of freedom. In our work in nucleon resonance physics, we investigate the excitation spectrum of the nucleon in terms of hadronic relativistic reaction theories that permit coupled-channels analyses of the experimental data.

Nuclear Phenomenology:

The GW group runs the Data Analysis Center (DAC) operating under the University-sponsored Center for Nuclear Studies. We maintain the world's most referenced and cited database for the spectroscopic studies of non-strange baryons in hadronic and electromagnetic nuclear processes. The DAC analyses are widely recognized for their importance to extract the fundamental properties of nuclear resonances from medium-energy nuclear physics data obtained at laboratories around the world.

Nuclear Astrophysics:

Astrophysics at GW enjoys a long tradition going back to George Gamow, the developer of the hot Big Bang Theory of the Universe. Now, with potential insight from new space-borne observatories, fundamental questions in nuclear physics, particle physics, and astronomy are converging. The GW group focuses on the physics underlying these new, high-energy astrophysical observations, working to answer some of these questions.

Graduate Studies in Nuclear Physics at **Georgia State University**



Georgia State University, a research university in the heart of downtown Atlanta, Georgia was founded in 1913 and serves over 30,000 students. It is one of the University System of Georgia's four research universities. Georgia State is the second largest of the 35 units in the University System of Georgia.



Nuclear People

| | |
|--------------------------|---|
| Faculty | 2 |
| Research scientist | 2 |
| Staff | 1 |
| Graduate students | 6 |

Group Website

<http://phynp6.phy-astr.gsu.edu/>

Departmental Website

<http://www.phy-astr.gsu.edu/>

University Website

<http://www.gsu.edu/>

Contact Information

Prof. Xiaochun He (xhe@gsu.edu)
Prof. Murad Sarsour
Department of Physics & Astronomy
Georgia State University
Atlanta, GA 30303
Tel: 404-413-6051

Research Areas

Relativistic heavy ion collision
Nucleon spin structure
Cosmic ray flux measurement
Weak interactions of low energy neutrons
Radiation interactions with matter

Other Research Areas in the Department

Condensed matter physics
Theoretical atomic physics
Astronomy/Astrophysics
Biophysics
Physics education research



Georgia State University



The Nuclear Physics Group at Georgia State University (GSU) is vibrant and growing. The group is a member of the PHENIX Collaboration studying matter properties at extremely high temperature and density and proton spin by colliding relativistic nuclei and polarized protons. The PHENIX experiment at the Relativistic Heavy Ion Collider at Brookhaven National Laboratory is located on Long Island, New York, USA.



The Nuclear Physics Group also studies cosmic ray radiation and cosmic ray shower simulation in the Earth's atmosphere. Multiple sets of cosmic ray flux counters have been built at GSU for the measurement of cosmic ray muons and neutrons in real-time.

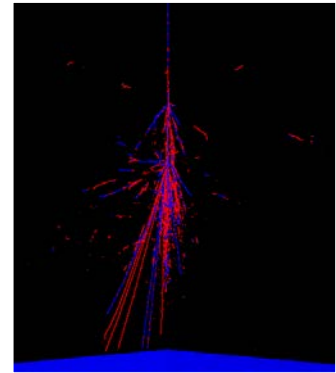

Atlanta is the capital and the largest city in Georgia. As of 2012 Atlanta had an estimated population of about 444,000 people. Its metropolitan area is the ninth largest in the country, inhabited by more than 5.5 million people.



Atlanta is considered to be a top business city and is a primary transportation hub of the Southeastern United States - via highway, railroad, and air. Atlanta contains the world headquarters of such large corporations as The Coca-Cola Company, Georgia-Pacific, AT&T Mobility, the Cable News Network, Delta Air Lines, and Turner Broadcasting.

Application deadline is February 15th for requesting assistantships. Other admission deadline is July 1st without assistantships. GRE verbal, quantitative and subject scores are required. Application should be done online: http://www.phy-astr.gsu.edu/new_web/2280.html

Graduate Studies in Nuclear Physics at Hampton University



Nuclear physics

| | |
|-------------------------------|----|
| Nuclear Experimental Faculty: | 3 |
| Theoretical Physics Faculty: | 2 |
| Postdoctoral Fellows: | 2 |
| Graduate Students: | 12 |

Rankings:

Best School of Science of all HBCUs in the United States

Application deadline:

June 1st (April 1st for internationals) for the Fall term

General university, department, and admissions information:

www.hamptonu.edu

Departmental web site:

science.hamptonu.edu/physics/

Application site:

gradcoll.hamptonu.edu/page/Admission-Requirements

Contact:

Dr. Paul Gueye (Department Chair)
(757) 727-5542

Paul.Gueye@Hamptonu.edu

Dr. Michael Kohl
Graduate Program Coordinator
(757) 727-5153

Michael.Kohl@Hamptonu.edu

General Info:

Hampton University was founded in 1868 as the Hampton Normal and Agricultural Institute shortly after the end of the American Civil War. In 1930 it became the Hampton Institute and turned into Hampton University in 1984. It is one of the leading Historically Black Colleges and Universities (HBCU) with the motto "The Standard of Excellence, An Education for Life". Hampton University is practicing the family idea, and due to its splendid location it is often called a "Home-by-the-sea". The picturesque university campus is well known for its natural beauty and numerous historical buildings. Extensive indoor and outdoor athletic facilities are available for general use by the university community. Through its 7 schools, it offers 80 academic programs leading to undergraduate and graduate degrees. The on-campus enrollment at Hampton University for the 2012 Fall semester was approximately 4,800, including 900 graduate students.

Nuclear physics research areas:

Intermediate Energy Nuclear Physics
Fundamental Interactions
Accelerator Physics
Nuclear Physics

Other broad research areas in the department:

Optical Physics
Nano Science
High Energy Physics



Nuclear and Applied Physics at Hampton University:

Students that pursue a graduate physics degree have vast opportunities to participate in cutting-edge research with world-renowned faculty and scientists at world-class facilities such as Jefferson Lab in Newport News, Virginia, Fermi Lab in Illinois, the National Superconducting Cyclotron Facility in Michigan, J-PARC in Japan, DESY in Germany and PSI in Switzerland.

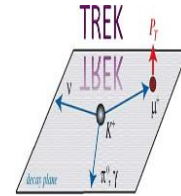

The Hampton University Proton Therapy Institute is a flagship facility for cancer treatment and the largest of its kind in the US. Hampton nuclear and medical physics faculty are actively involved in detector development on campus.

Research at Jefferson Lab

Jefferson Lab is a National User Facility funded by DOE, located in close proximity (<10 miles) to the campus of Hampton University and uses up to 12-GeV electron beams to investigate the nature of the strong interaction and QCD phenomena, and to search for New Physics beyond the Standard Model. Hampton University nuclear physics faculty are involved in leading roles in the research program at Jefferson Lab and at the FEL facility.



Website: www.jlab.org

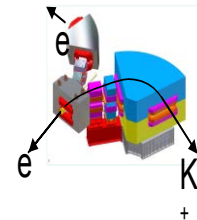

About Hampton:

Hampton University is nestled along the banks of the Virginia Peninsula, near the mouth of the Chesapeake Bay. The surrounding city of Hampton features a wide array of business and industrial enterprises, retail and residential areas, historical sites, and miles of waterfront and beaches. Attractions such as [Fort Monroe](#), [NASA Langley Research Center](#), and the [Virginia Air and Space Center](#) add to the splendor of the HU campus.



Graduate Studies in Nuclear Physics at The University of Idaho



Nuclear People:

| | |
|------------------------------------|---|
| Theoretical Faculty: | 2 |
| Graduate Students: | 2 |
| Undergraduate (research) Students: | 2 |
| Female faculty: | 1 |

Rankings :

The University of Idaho is recognized as one of the Best Value Colleges in America by the The Princeton Review.

Application deadline:

For priority admission:
February 1 (Fall admission) and
September 1 (Spring admission).

General university, department, and admissions information:

www.uidaho.edu

Departmental web site:

www.uidaho.edu/sci/physics

Application site:

www.uidaho.edu/cogs

Contact in Nuclear Physics:

Francesca Sammarruca
(208) 885-6738
fsammarr@uidaho.edu
Ruprecht Machleidt
(208) 885-6380
machleid@uidaho.edu

General Info:

The University of Idaho is located in Moscow, in the beautiful rolling hills of northwestern Idaho. Our small but high-quality physics department offers research opportunities in nuclear physics (theory), condensed matter (experiment), biophysics (computational and experimental), and astronomy.

Extensive indoor and outdoor athletic facilities are available to the university community.

The total number of students is about 12,000, with approximately 2000 graduate students.

The relative proximity to Seattle allows easy trips to the Institute of Nuclear Theory (INT).

Furthermore, collaborations are possible with the Idaho National Laboratory (INL), located in southern Idaho.

Nuclear physics research areas:

Theories of nuclear forces
Nuclear structure
Nuclear reactions
Nuclear astrophysics

Other broad research areas in department:

Condensed matter physics
Biophysics
Planetary science

The University of Idaho



Research Interests:

We are involved with a broad spectrum of studies aimed at improving our knowledge of nuclear matter and its extreme states in terms of density, asymmetry, and temperature. The nuclear matter properties we calculate have relevance for the physics of rare, short-lived nuclei as well as the nuclear physics of neutron stars.

With the Facility for Rare Isotope Beams (FRIB) recently approved for design and construction at Michigan State University, theoretical studies of neutron-rich systems, such as those we pursue, become especially important and timely.

We are also concerned with refining our understanding of nuclear forces in terms of the fundamental theory of strong interactions, quantum chromodynamics (QCD). The connection to QCD is made through chiral effective field theory (EFT), which is constructed in terms of hadronic degrees of freedom and encodes the low-energy symmetries of QCD and the pattern of their breaking. Improved EFT-based nuclear forces will have widespread impact on our understanding of nuclear structure and reactions.

Our research is funded by the U.S. Department of Energy.



About Moscow:

Moscow is a small town (about 25,000 residents) with high quality of life. We are only about a 5-hour drive from Seattle and surrounded by the beauty of the Pacific Northwest. Moscow is 5 miles from Pullman, Washington, home of Washington State University. The close proximity of the two universities facilitates numerous and diverse cultural activities. We experience warm and dry summers, beautiful falls, and snowy winters.



Graduate Studies in Nuclear Physics

The University of Illinois at Chicago

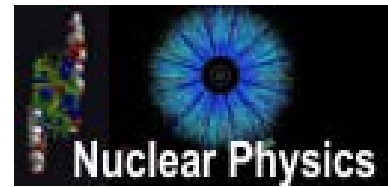

One of the world's best young universities; ranked 4th in the US and 18th worldwide*

* <https://www.timeshighereducation.com/world-university-rankings/2015/one-hundred-under-fifty>



Department of Physics

Research Expenditures: \$4.1M/yr
Faculty: 25
Postdocs & Research Faculty: 16
Graduate Students: 80

Application Deadlines

February 15 (all international students and priority deadline for domestic students)
May 15 (final deadline for domestic students, but all seats may be filled by this date)

Departmental Web Site

www.phys.uic.edu

Group Contacts

Olga Evdokimov evdolga@uic.edu
David Hofman hofman@uic.edu
Misha Stephanov misha@uic.edu
Zhenyu Ye yezhenyu@uic.edu
Ho-Ung Yee hyyee@uic.edu

General Information

The University of Illinois at Chicago is one of the top 200 research-funded institutions worldwide, located in the heart of a world class city on one of the world's great lakes. Chicago surrounds the UIC campus, stretching in every direction and offering extraordinary cultural and intellectual opportunities.

The largest university in the Chicago area, UIC has over 29,000 students, 15 colleges, including the nation's largest medical school, and annual research expenditures exceeding \$347 million. Students at UIC reflect the international character of Chicago, and our student body is proudly recognized as one of the nation's most diverse.

The nuclear group at UIC originated in 1991 when two faculty began high energy heavy ion research at Brookhaven National Laboratory. Group members are currently participating in the STAR and CMS experiments and collaborate closely with the RIKEN BNL Research Center and Central China Normal University. Both experimental and theoretical groups are funded by the U.S. Department of Energy.

Nuclear Physics Research Areas

Relativistic heavy ion collisions
The quark gluon plasma
Strong interactions
Matter in extreme conditions

Other Broad Research Areas in Department

| | |
|----------------------------|----------------------|
| Applied Laser | Materials |
| Biological and Soft Matter | High Energy Particle |
| Condensed Matter | Renewable Energy |



Brookhaven National Lab

Located on Long Island, just 20 miles from New York City, BNL is one of the most powerful multidisciplinary research laboratories in the United States. Prof. Ho-Ung Yee is a RIKEN/BNL Fellow and UIC is a member of the STAR Collaboration at the Relativistic Heavy Ion Collider located at BNL. Our primary physics interest is to study the formation and characteristics of the quark gluon plasma, a state of matter believed to exist at the beginning of the universe.



CERN - Geneva, Switzerland

If you have dreamt of visiting a historic European city, you can take a quick tram into Geneva, Switzerland after a day (or night) of experimental shift. The new frontier of high-energy physics, the Large Hadron Collider at CERN, is operating on the Swiss-French border to take our view of nuclear matter to a new paradigm. UIC is one of the DOE funded university groups approved to work on experimental heavy ion research at the Compact Muon Solenoid (CMS) detector.



Fermilab

Fermilab, the premiere high energy laboratory nationwide, is also the center for CMS research in the U.S. Fermilab is only 30 miles from the UIC campus and is the home of the largest CMS Tier-1 Computing Center in the world. Despite being located 4400 miles from CERN, Fermilab's remote control room (shown left) provides real-time access and control to the CMS detector.

About Chicago and UIC:

The UIC campus is located just west of the Chicago downtown “loop” area, and is easily accessible via three major interstate highways, two local “L” subways, numerous CTA buses, and Metra trains that reach out to the surrounding suburbs. O’Hare and Midway airports are a quick subway ride away. Chicago is a center of physics activity with several major universities and national laboratories located nearby. Chicago offers 150 theaters, such as The Goodman Theater or Second City, and 40 museums including the Museum of Science and Industry, the Art Institute, and the Field Museum. Music can be heard from the splendor of Orchestra Hall to the excitement of outdoor concerts in Millennium Park to jazz and blues in local musical venues and neighborhood pubs. Architecture in Chicago is world-renowned for its innovation and beauty, providing a spectacular city skyline a short walk from beautiful Lake Michigan beaches.



Chicago at Sunrise, Copyright 1998 Brian P. Lawler

Graduate Studies in Nuclear Physics at Indiana University and the Center for the Exploration of Energy and Matter (CEEM)



Nuclear People:

| | |
|------------------------------|----|
| Experimental Faculty: | 8 |
| Theoretical Faculty: | 4 |
| Accelerator Physics Faculty: | 1 |
| Postdocs: | 8 |
| Graduate Students: | 30 |

Rankings:

#5 Graduate Nuclear Physics program,
U.S. News & World Report

Application deadline:

Dec 1 for international applicants,
January 15 for domestic applicants

General university, department, and admissions information:

www.iub.edu

Departmental web site:

www.physics.indiana.edu
www.ceem.indiana.edu

Application site:

www.admit.indiana.edu

Contact in Nuclear Physics:

Mike Snow
(812) 855-7914
wsnow@indiana.edu

General Info:

Indiana University was founded in 1820. IU has over 120 majors and programs ranked in the nation's top 20 and is rated among the top 100 universities in the world thanks to 25 years of visionary leadership by Hermann B Wells, one of the greatest university president/chancellors of the 20th century. IU offers instruction in over 80 languages, was the first university to offer a degree in folklore and a doctorate in gender studies, and possesses the top-ranked Jacobs School of Music, the School of Public and Environmental Affairs, the Lilly Library, and the Kinsey Institute. IUB is consistently rated among the best campuses in the US in computing resources. Students come from all 50 states in the US and more than 159 countries. Typical on-campus enrollment at IUB is approximately 40,000, including about 10,000 graduate and professional students.

Nuclear physics research areas:

Accelerator physics
Nuclear reactions/heavy ion collisions
Neutron physics/weak interactions
Neutrino physics
Double beta decay
Precision measurement/symmetry violation searches
Angular momentum of gluons and quarks in the proton
Hadron spectroscopy
Neutron star composition and dynamics
QCD theory

Other broad research areas in department:

Astrophysics
Biophysics/Biocomplexity Institute
Condensed matter physics
Elementary particle physics

Indiana University

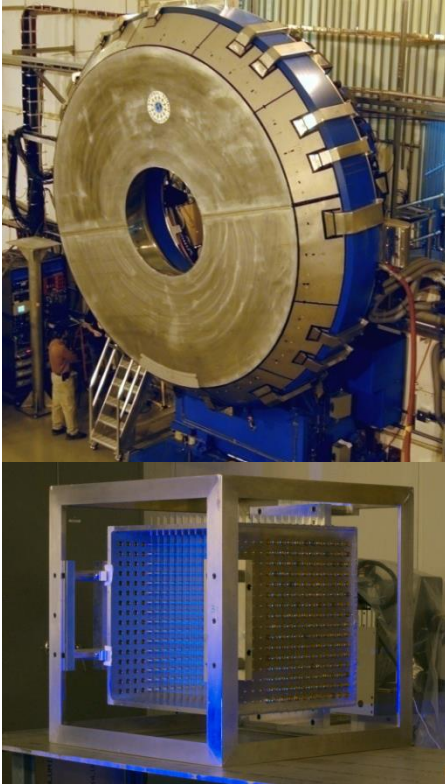

Center for Exploration of Energy and Matter (CEEM)

The Indiana University Center for the Exploration of Energy and Matter (CEEM) is a multipurpose research lab located on the campus of Indiana University/Bloomington. The staff, faculty, and students at CEEM conduct research in nuclear/particle physics, materials science, gravity, and accelerator physics. CEEM houses both the research labs and construction and assembly facilities for the IU experimental nuclear physics group and the site of the IU Nuclear Theory Center. The experimental nuclear physics group is active in neutrino oscillation and cross section measurements, double beta decay, neutron weak interactions, nuclear reactions, QCD spin physics, and searches for electric dipole moments. Nuclear theorists are active in QCD/strong interaction theory and in applications to astrophysics. CEEM operates the Low Energy Neutron Source (LENS) for neutron physics, scattering, and imaging and hosts the ALPHA electron storage ring for accelerator physics studies and defense applications. CEEM members also participate in the IU Center for Spacetime Symmetries and conduct measurements relevant to constrain possible CPT/Lorentz violation. Pictures show the STAR endcap calorimeter and the Scibath neutrino detector.

Website: www.ceem.indiana.edu

Indiana University Physics Department:

The IU nuclear physics group is part of a larger effort at IU in nuclear physics, particle physics, and astrophysics. IU faculty in experimental high energy and neutrino physics play leadership roles in collider physics (ATLAS and D0), neutrino oscillation physics (MINOS, NOVA, and LBNE), strong interaction physics (CLEO, BESII, and GlueX) and astrophysics (SNAP and CREST). IU faculty in theoretical high energy physics are active in lattice gauge theory, Lorentz and CPT violation, and beyond-Standard Model phenomenology. Thirty-three IU faculty are active in these areas.

Website: www.physics.indiana.edu



About Bloomington:

The flagship campus of Indiana University, located in Bloomington, is widely considered to be one of the most beautiful college campuses in the US. Bloomington is a small college town of ~70,000 city residents (including the university) and ~175,000 in the metro area. Located in the southwestern portion of the state, the city is surrounded by rolling hills and a woodland environment with several nearby lakes, state forests, and wetlands. The city hosts several national and international music and arts festivals, musical performances, and theatrical acts. The Wonderlab science museum and the Tibetan Mongolian Buddhist Cultural Center (pictured) also attract many visitors.

Website: www.visitbloomington.com



Graduate Studies in Nuclear Physics at the University of Iowa

**Application deadline:**

January 15 for Fall
October 1 for Spring

Departmental web site:

www.physics.uiowa.edu

Application site:

www.physics.uiowa.edu/graduate/apply.html

Contact in Nuclear Physics:

Wayne Polyzou
Phone: (319) 335-1856
E-mail:
polyzou@uiowa.edu



Iowa graduate students using test beam at Fermi National Lab.

General Info:

The nuclear physics faculty includes experimentalists Chaden Djalali, Jane Nachtman, and Yasar Onel and theorists Fritz Coester, William Klink, Gerald Payne, and Wayne Polyzou.

Much of the experimental nuclear program is directed toward the study of nuclear reactions at the highest available energies such as Pb + Pb at 1100 TeV. These studies make use of the CMS detector at the LHC, the huge new colliding beam machine at CERN (in Geneva, Switzerland). Iowa has contributed strongly in the construction of two key detectors for the CMS Heavy ion program. These are the HF (Forward Quartz Fiber Calorimetry), ZDC (Zero Degree Calorimetry) and remote controlled ZDC removal crane. Iowa is a lead institute for upgrading the HF detector and also involved in the upgrade of the ZDC detector systems.

Graduate students are involved in all stages of the experimental nuclear physics research, from developing detectors to the analysis and interpretation of data.

Iowa is also participating in the building and commissioning of the FTOF (forward time of flight) detector which is part of the CLAS12 upgrade in Hall B of the CEBAF accelerator at the Thomas Jefferson National Laboratory. CLAS12 combined with the 11 GeV electron beam will be a state of the art detector to study the properties of hadrons and mesons in the non perturbative regime of QCD.

Theoretical research focuses on few-body nuclear physics at energy scales of a few GeV. Understanding physics at this energy scale provides insight for understanding how a description of nuclei based on nucleon and meson degrees of freedom emerges from a description based on quark and gluon degrees of freedom.

The nuclear physics programs are supported primarily by grants from the U.S. Department of Energy. The financial package for graduate students is generous, and the cost of living is moderate.

University of Iowa



Van Allen Hall



IATL



LHC tunnel at CERN

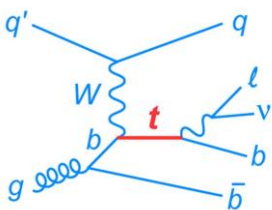

The University of Iowa Department of Physics and Astronomy is located in two buildings, Van Allen Hall and the Advanced Technology Laboratories (IATL).

Research areas involving Nuclear Physics:

- Particles and fields
- Mathematical physics
- Astronomy and astrophysics
- Space physics
- Plasma physics and fusion
- Medical imaging and positron emission tomography (PET)

Other research areas in department:

- Atomic and molecular physics
- Condensed matter and materials
- Photonics and quantum electronics

About University of Iowa:

The University of Iowa is a major national research university located on a beautiful 1,900-acre campus in Iowa City, on the Iowa River. The U of Iowa Hospitals and Clinics and the Dental School provide excellent health care. The University both provides and attracts a wide variety of cultural opportunities as well as Big Ten athletic events. Renowned for its writing programs, the UI attracts top writers from all over the world. The large music program at the University results in many opportunities to enjoy music and to participate in it.

In the summer, Iowa City sponsors weekly downtown jazz and pop concerts, and all through the year major poets, writers, artists, historians, scientists, and others speak or perform in University venues or read at local bookstores.

Excellent public schools, close, safe, and comfortable neighborhoods, and a highly educated population mean that Iowa City frequently appears high on “best-place-to-live” listings in national magazines. The nearby countryside, good state parks, and the Iowa River provide many opportunities for walking, biking, and boating.

The Iowa City-Cedar Rapids metropolitan area has a population of a quarter million and includes the Eastern Iowa Airport. It is within easy travel distance to Chicago, Minneapolis, Omaha, and St. Louis.

Graduate Studies in Nuclear Physics at Iowa State University

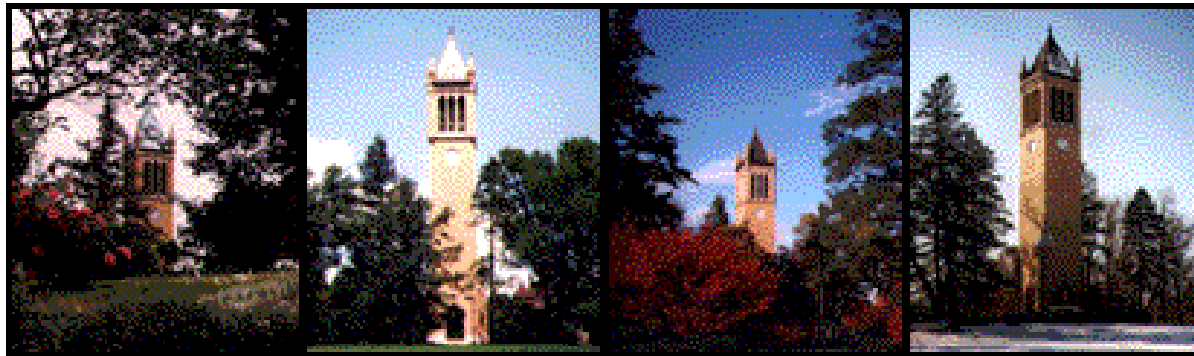

Nuclear People:

| | |
|-----------------------------|---|
| Experimental Faculty: | 3 |
| Theoretical Faculty: | 2 |
| Research Faculty and Staff: | 2 |
| Postdoctoral Fellows: | 4 |
| Graduate Students: | 9 |

Application deadline:

February 15th

Departmental web site:

<http://www.physastro.iastate.edu/>

Application site:

<http://www.physastro.iastate.edu/grad>

Contact for Nuclear Physics:

Prof. Marzia Rosati
(515) 294-8573
mrosati@iastate.edu

General Info:

Iowa State University was founded in 1858 to make higher education accessible to all and to teach liberal and practical subjects. Iowa State is a leader in agriculture, engineering, extension, home economics, and was the nation's first state veterinary medicine school in 1879. The Iowa State University campus is in the middle of Ames which offers a mix of small-town friendliness and safety with all of the amenities of a much larger city. The on-campus enrollment at Iowa State University for the 2016 fall semester was approximately 36,000, including 5,000 graduate students.

Nuclear physics research areas:

Relativistic Heavy Ions
Spin Structure of Nucleons
Strong interaction theory
Computational Physics
Ab initio Nuclear structure

Other broad research areas in department:

Astronomy and astrophysics
Biophysics
Condensed matter physics
Elementary particle physics

The Nuclear Physics Theory and Experiment groups at Iowa State are focused on the study of fundamental Quantum Chromodynamics (QCD). There is a great deal of synergy between both efforts, and an active exchange between both groups provides a vibrant research atmosphere. Both groups have excellent opportunities for new graduate students in physics in nuclear physics. Graduate students who earned their Ph.D. in our groups in the last five years have chosen to pursue a career in academia (65%) or in industry (35%) and were all successfully employed by the end of their ISU appointment. Our groups are supported by \$1M grants annually.

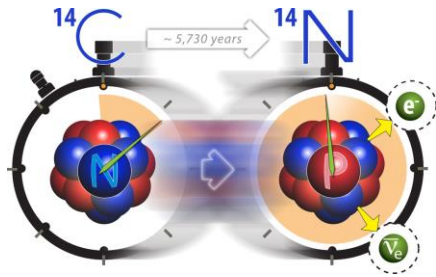
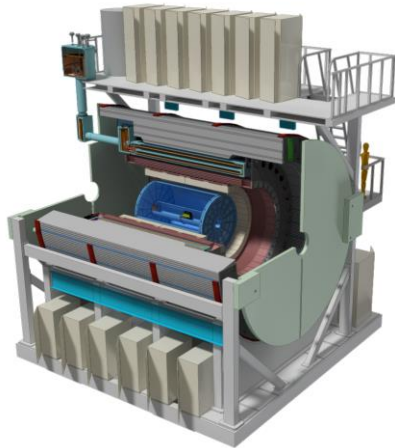

The Nuclear Physics Experimental group is actively involved in the PHENIX experiment at the Relativistic Heavy Ion Collider at Brookhaven National Laboratory. The faculty have leadership roles in PHENIX and sPHENIX, including Deputy Spokesperson, Project Directors of upgrades, and conveners of physics working groups. These faculty are invited to present their research at several international conferences each year. Areas of research include quarkonia production and suppression, bulk properties of the Quark Gluon Plasma, hard scattering probes of strongly interacting matter, and the spin structure of hadrons. We are involved in several hardware projects. We are currently leading the effort on the construction, testing and installation of the MPC-EX preshower detector.

The Nuclear Physics Theory group primary goals are fundamental descriptions of nuclear phenomena relevant to experiment. Our balanced program consists of developing and applying (1) QCD for high-energy nuclear collisions, and (2) non-perturbative many-body theory for strong interactions. We are developing first principles treatments of physical observables in present and future experiments at Fermilab, RHIC, JLab, and LHC. We are also developing a non-perturbative framework for strongly interacting many-body systems including a covariant Hamiltonian framework for solving quantum field theory in non-perturbative domains. Our program aims to address the properties of hadronic matter under extreme conditions and fundamental properties of nuclei at high precision.

About Ames

Located in the heart of Iowa, Ames combines small-town living with big city recreation, sporting and cultural activities. Ames has hundreds of acres of parks, numerous bike paths, and cultural festivals and celebrations and has been ranked the 8th best places to live in the nation (Money magazine 2014)

Graduate Studies in Nuclear Physics at the University of Kentucky

Nuclear physics group:

| | |
|---------------------------|----|
| Experimental faculty: | 7 |
| Theoretical faculty: | 1 |
| Post-docs: | 4 |
| Graduate Students: | 22 |
| Female faculty: | 2 |
| Female graduate students: | 5 |

Departmental web site:

www.pa.uky.edu

Graduate application site:

www.pa.uky.edu

Contact in Nuclear Physics:

Prof. Chris Crawford
crawford@pa.uky.edu



Muon $g - 2$ Experiment at Fermilab

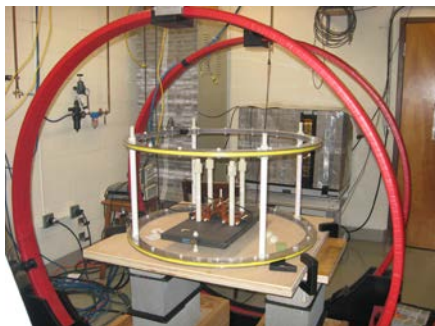

Faraday Rotation Lab at U. Kentucky

General Information.

The University of Kentucky (UK), established in 1865, is a public, land-grant, research university with an enrollment of 23,000 undergraduate students and 7,000 graduate students. The University is located near downtown Lexington, a metropolitan area of nearly 490,000 people. Lexington is in the heart of the famous Bluegrass region of central Kentucky and is about 80 miles from both Louisville, KY and Cincinnati, OH.

The Department of Physics and Astronomy comprises approximately 30 faculty, 75 graduate students, and 100 undergraduate majors. Among its faculty are 11 Fellows of the American Physical Society and multiple award-winning researchers and teachers. The Department is home to the Center for Advanced Materials, a Van de Graaff accelerator laboratory, and the MacAdam Student Observatory.

The nuclear physics group includes a low energy experimental group based in our in-house 7 MV Van de Graaff laboratory, experimental groups using national and international laboratories (Fermilab, JLab, LANL, ORNL, PSI, RHIC, SNS, and TRIUMF), and a theoretical group. The group's research activities range from studies of the sub-structure and underlying symmetries of complex nuclei, the quark and gluon structure of neutrons, protons, and other hadrons to high-precision tests of the Standard Model and measurements of the fundamental constants of nature to studies of dark matter and dark energy.

Nuclear physics research areas:

Fundamental interactions and symmetries, nuclear astrophysics, hadronic structure, nuclear structure.

Other department research areas:

Astronomy/Astrophysics and Cosmology, Experimental and Theoretical Atomic Physics, Experimental and Theoretical Condensed Matter Physics, Theoretical Particle Physics and String Theory.

Fundamental interactions:

We are conducting experiments with beams of muons and neutrons to explore the fundamental interactions of nature. Our measurements will determine fundamental constants of the Standard Model, test the underlying symmetries of the Standard Model, and probe new physics. Additionally, our theory group studies the way such symmetries are revealed in the decays and interactions of strongly-interacting particles - a linchpin in disentangling the character of the basic symmetries from the complexity of the strong force. Theoretical studies also address the nature of dark matter and dark energy.

Our neutron experiments, conducted with cold and ultracold neutrons at the Spallation Neutron Source (SNS) at Oak Ridge and at an ultracold neutron source at Los Alamos, probe the symmetries of the weak force, such as parity, charge-conjugation, and time-reversal, via precise measurements of neutron beta-decay, neutron capture by protons and other nuclei, and the quest to discover an electric dipole moment (EDM) of the neutron. Our muon experiments are conducted with the intense muon beams available at the Paul Scherrer Institute (PSI) near Zurich, Switzerland and at Fermi National Accelerator Laboratory (FNAL). Muon experiments at PSI utilize the capture of muons by protons and deuterons to study aspects of the weak interaction, and a new muon experiment at FNAL will carry out a precise measurement of the muon magnetic moment anomaly for a precision test of the Standard Model.

Hadron structure:

We are also conducting experiments using beams of photons, electrons, and protons to study the basic properties and underlying quark-gluon structure of neutrons and protons. Neutrons and protons are complex, strongly-interacting systems of quarks and gluons, and the detailed understanding of their flavor, spin, and charge current distributions is a central problem in nuclear physics. Experiments are underway with photons at the HIGS Facility at Duke University and with electrons at Jefferson Lab in Virginia. The photon scattering experiments address the neutron's electromagnetic polarizability – a quantity reflecting the deformation of a neutron in an external electromagnetic field. Electron scattering experiments at JLab aim at measurements of the quark sub-structure of the neutron.

Our group is also a member of the STAR Collaboration at the Relativistic Heavy Ion Collider (RHIC) located at Brookhaven National Laboratory (BNL). The spin program at STAR, utilizing the high-energy polarized proton-proton collisions at RHIC, is determining the contribution of gluons to the total spin of the proton.

Nuclear structure:

Our in-house 7-MV Van de Graaff accelerator is capable of producing sub-nanosecond pulses of light ions, which can be used for generating pulses of neutrons. These monoenergetic, sub-nanosecond neutrons enable us to investigate neutron-induced reactions with very low backgrounds and study various properties of nuclei. Through these reactions, we examine the structure of complex nuclei and determine nuclear level lifetimes that are inaccessible with other methods.

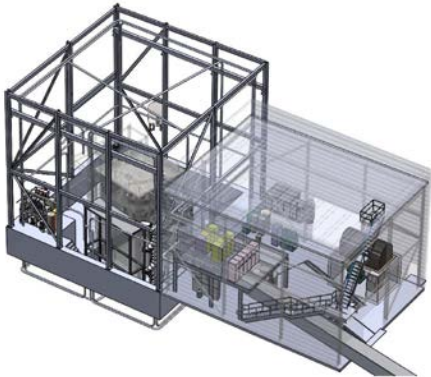

Neutron EDM Experiment at Oak Ridge

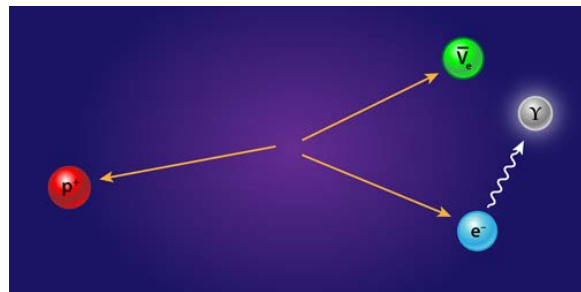

Theoretical Research in Radiative Neutron Decay

Louisiana State University

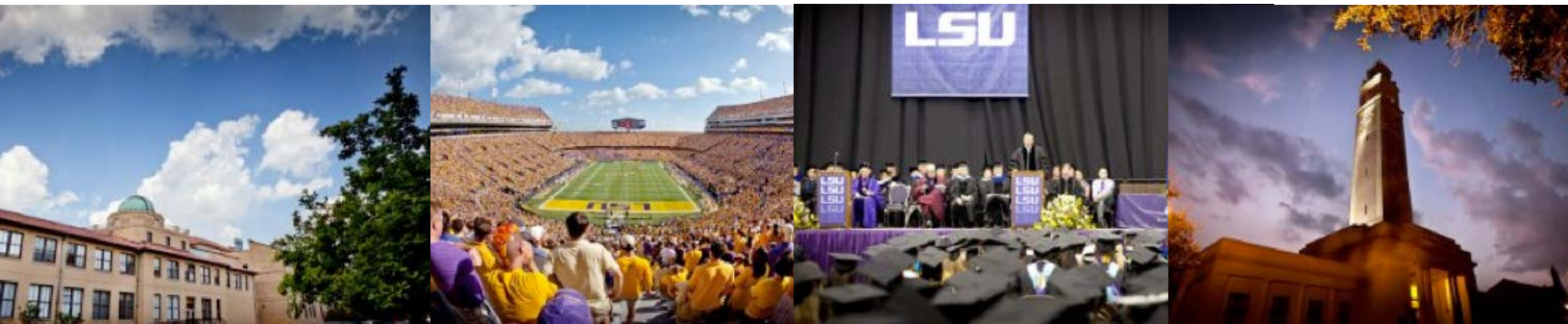

Nuclear & Particle Physics Group

Experimental faculty: 6
Theoretical faculty: 2
Postdocs: 5
Students: 12

Contacts

Jeff Blackmon (experimental nuclear)
blackmon@phys.lsu.edu

Catherine Deibel (experimental nuclear)
deibel@phys.lsu.edu

Jerry Draayer (theoretical nuclear)
draayer@phys.lsu.edu

Thomas Kutter (experimental particle)
kutter@phys.lsu.edu

Kristina Launey (theoretical nuclear)
kristina@phys.lsu.edu

Scott Marley (experimental nuclear)
smarley@lsu.edu

James Matthews (experimental particle)
matthews@phys.lsu.edu

Martin Tzanov (experimental particle)
mtzanov@phys.lsu.edu

Application Deadline
January 15 (first round)

Department Website
www.phys.lsu.edu

General Information

Louisiana State University is located in Baton Rouge, the state capital of Louisiana. Founded in 1860, LSU is the flagship institution of the state of Louisiana and is one of only 30 universities nationwide holding land-, sea-, and space-grant status.

LSU has a diverse student body consisting of more than 30,000 students including over 1,700 international students and 6,000 graduate students. With over 1,500 faculty members and a staff of more than 5,000, LSU is one of the most competitive research institutions in the southern United States.

The Department of Physics and Astronomy at LSU has over 50 faculty members with a variety of research interests and collaborations including LIGO, the Pierre Auger observatory, and the Mary Bird Perkins Cancer Center.

Nuclear physics research areas

Nuclear structure, nuclear astrophysics, neutrino physics, nuclear theory, computation physics, particle physics

Other departmental research areas

Observational astronomy, condensed matter, material physics, AMO and quantum physics, gravitational physics, medical physics, theoretical general relativity

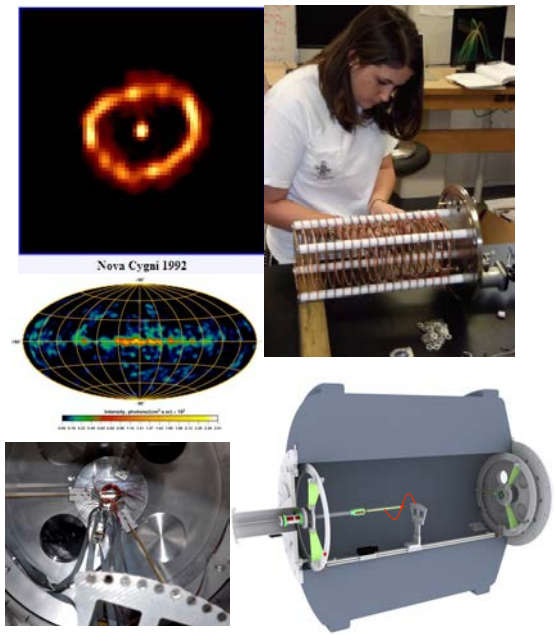

Experimental Nuclear Research

The nuclear physics group at LSU has an active research program studying experimental nuclear structure and astrophysics. By performing direct reaction studies and indirect studies of nuclear structure we determine how the heavier elements were created in explosive stellar environments and attempt to explain the structure of those nuclei. In the laboratories at LSU, detectors are developed and tested to be used in reaction studies at accelerator facilities in the US and worldwide. These nucleosynthesis studies are performed at laboratories such as the National Superconducting Cyclotron Laboratory (NSCL) at MSU, Argonne National Laboratory, Florida State University, and TRIUMF laboratory among others, and will continue at future facilities such as the Facility for Rare Isotope Beams (FRIB).

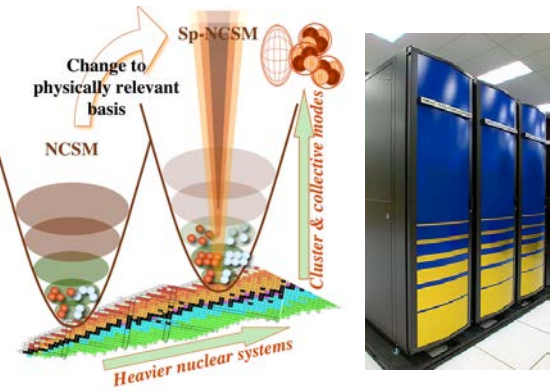

Theoretical Nuclear Physics

The theoretical nuclear physics program at LSU focuses on the low-energy structure of atomic nuclei - from light to heavy mass - by using algebraic (group theoretical), many-body theory, and high-performance computing methodologies. By utilizing symmetries inherent to the nuclear dynamics, we are able to extend the reach of no-core shell models beyond current limits to study both nuclear structure and reactions important in nuclear astrophysics and neutrino physics.

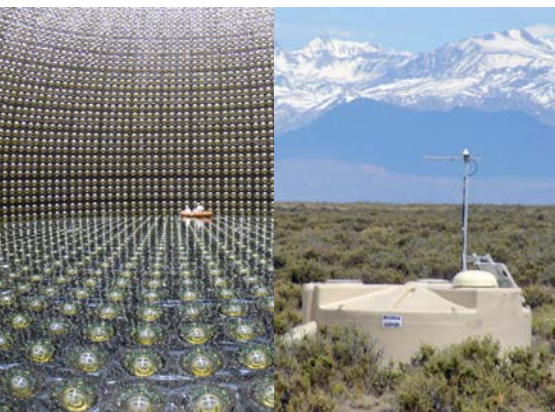

Particle Physics

The particle physics group at LSU is involved in studying properties of neutrinos and cosmic rays. Our group is involved in ongoing research at the T2K detector in Japan to measure neutrino oscillations, θ_{13} and search for CP violation in the neutrino sector. At the Pierre Auger observatory in Argentina, we are currently measuring the energy direction and composition of the highest energy cosmic rays to determine their origin, which is heretofore unknown.

About Baton Rouge

Baton Rouge is located approximately 80 miles northwest of New Orleans along the Mississippi River. With mild, short winters and warm weather year round, it is easy to experience the distinctive culture that exists in Baton Rouge. Great music and art, amazing cajun food, and of course Mardi Gras are just a few of the highlights of this truly unique city.



Graduate Studies in Nuclear and Astroparticle Physics at University of Massachusetts Amherst



Nuclear physics and particle astrophysics people

| | |
|------------------------------|----|
| Faculty | 9 |
| Emeriti and visiting Faculty | 4 |
| Postdoctoral researchers | 7 |
| Graduate students | 12 |

Application deadline

January 15th

How to apply

<http://www.physics.umass.edu/graduate/prospective>

Information

<http://www.physics.umass.edu/graduate/prospective/letter>

Physics department

<http://physics.umass.edu>

Nuclear physics

<http://blogs.umass.edu/nuclear/>

Fund. interactions theory

<http://blogs.umass.edu/het/>

ACFI

<http://www.physics.umass.edu/acfi/>

General information - A college town of 35,000 people, Amherst is located in the Pioneer Valley of Western Massachusetts. With a definite New England character and immersed in rural surroundings, it has a strong academic and cultural identity. Founded in 1863 as an agricultural college, UMass Amherst is a public research university and the flagship campus of the University of Massachusetts system. Enrollment tops 21,000 undergraduate and 6,000 graduate students. The physics department counts 36 faculty and about 90 graduate students. It hosts the Amherst Center for Fundamental Interactions (ACFI) that addresses physics questions at the interface of the intensity, cosmic and energy frontiers. UMass Amherst is a member of the Five College Consortium which also includes Amherst, Hampshire, Mount Holyoke, and Smith Colleges.

Nuclear physics experiment - Low-E QCD; Proton spin structure and spin polarizability; Search for new physics with $(g-2)$ of the muon; Searches for electric dipole moments and CP-violation in leptons and nuclei; Solar neutrinos; Neutrino-less 2β decay; Searches for sterile neutrinos; Weakly interacting dark matter.

Nuclear physics theory - CP-violation, electric dipole moments, origin of matter; Effective field theories of QCD; Non-equilibrium QFT; EW symmetry-breaking; Physics beyond the Standard Model; Origin of neutrino mass, lepton flavor and lepton number non-conservation; EW baryogenesis, dark matter, and the LHC; Tests of fundamental symmetries.

Other research areas - Theoretical gravity and cosmology; High energy elementary particles; Hard and soft condensed matter physics; Low temperature physics; Nanoscale physics; Strongly correlated quantum systems; Biophysics. Astronomy and Polymer Sciences have dedicated departments.

UMass Amherst

Crystal Ball detector at Mainz



Muon g-2 E989

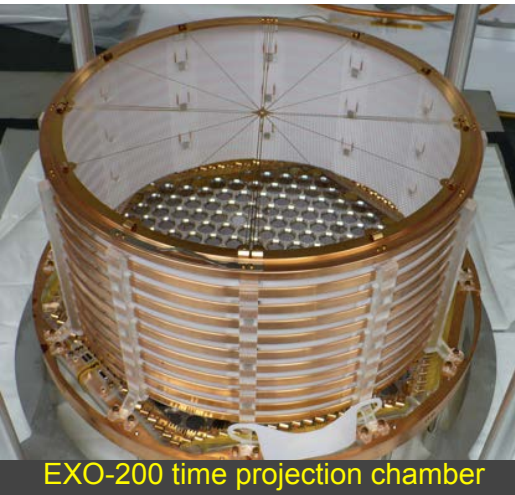

EXO-200 time projection chamber



LUX inner detector

The **Theoretical Nuclear Physics Group** provides leadership for the fundamental symmetries and neutrinos, and hadron structure core areas of nuclear physics. The significant interface of its activities with the experimental programs, and with high energy physics, cosmology and astrophysics in the entire Amherst area are enhanced by the presence of the Amherst Center for Fundamental Interactions (ACFI).

The **Experimental Nuclear and Particle Astro- Physics groups** focus on low and medium energy tests of the fundamental symmetries of nature. Group members work in collaborative experiments housed at laboratories in North America and Europe. Experiments currently running and projects in the planning and design phases provide a balanced mix of experimental opportunities.

Jefferson Lab (Newport News, VA) - High precision polarized electron scattering experiments that measure the neutron skin of heavy nuclei (PREX). A beam of linearly polarized photons is used for low energy tests of QCD (PRIMEX, GLUEX).

Gran Sasso National Lab (Assergi, Italy) - The low muon flux surviving at this deep underground site is ideal to detect solar neutrinos and search for the existence of sterile neutrinos (Borexino/SOX), and search for weakly interacting massive particles (WIMPs), as constituents of dark matter (DarkSide).

Sanford Underground Research Facility (Lead, SD) - Even deeper than Gran Sasso, the Homestake mine is home to the LUX experiment, which currently holds the best sensitivity for WIMP detection. A larger, more sensitive experiment (LZ) is in the project phase.

Fermilab (Batavia, IL) - A new experiment to measure the anomalous magnetic moment of the muon with sensitivity to new physics (Muon g-2 E989)

MAMI Accelerator (Mainz, Germany) - Spin polarizability of the proton is studied using beams of polarized photons (A2).

Waste Isolation Pilot Plant (Carlsbad, NM) - A search is on for neutrino-less 2β decay of Xe-136 (EXO-200). A second generation experiment is in the design phase, which will possibly be located at SNOLab (nEXO).

Other experimental activities (at UMass Amherst) - A new high sensitivity molecular beam experiment to search for fundamental symmetry violations in nuclei; Laboratories for detector development, computer clusters; A machine shop.; A new Physical Science Building is scheduled to open Spring '18.

Graduate Studies in Nuclear Physics at University of Massachusetts Lowell



Department Statistics:

| | |
|-------------------------|------|
| Faculty: | 24 |
| Nuclear Faculty (expt): | 3 |
| Graduate Students: | ~70 |
| Undergraduate Students: | ~100 |
| Nuclear Post-docs: | 2 |

Application deadline:

January 15 for financial aid

Departmental web site:

www.uml.edu/physics

Graduate application site:

www.uml.edu/grad

Graduate Program Contact:

Partha Chowdhury
Graduate Coordinator
(978) 934-3730
Partha_Chowdhury@uml.edu

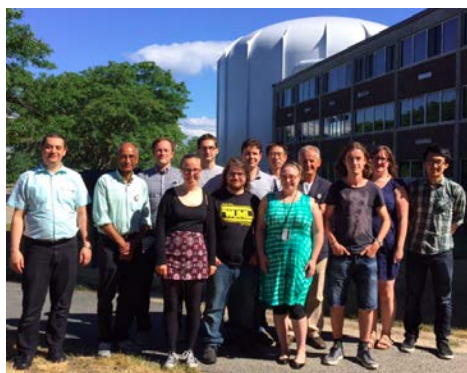

The Nuclear group at UMass Lowell

General Info:

Leading edge research lies at heart of graduate programs in physics. With over \$8M annually in funded research, the department was recently ranked by the National Science Foundation in the top 50 nationwide in R&D expenditures. Our graduates hold positions in academia, national laboratories, government agencies, major medical facilities, and industry. Located in the historic industrial city of Lowell, 25 miles northwest of Boston, the UMass Lowell campus is nestled in a sharp bend in the Merrimack River. The university, which is rising fast in national rankings, offers more than 17,000 students 170+ degree choices, internships, bachelor's to master's programs and doctoral studies, with a strong reputation in science, engineering and technology.

Nuclear related research areas:

Nuclear Structure and Nuclear Astrophysics
Advanced Radiation Detection and Imaging
Neutron Physics and Radiography
Nuclear Techniques in Materials Research
Radiological Health and Medical Physics

Other broad research areas in department:

Astro/Space/Atmospheric Physics
Terahertz Technologies
Photonics and Biophotonics
Advanced Materials
Femtosecond Lasers/Nanoscience
Soft Condensed Matter
Quantum Information
Cosmology and Gravitation



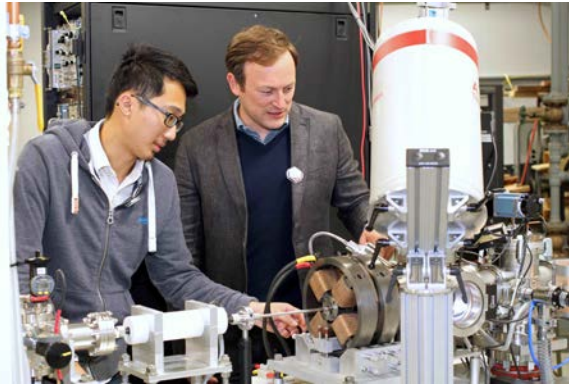

Proton microbeam facility at the Van de Graaff accelerator

Radiation Laboratory:

The Radiation Laboratory is a unique research center in the five-campus UMass system, with a 1-MW research reactor, a 5.5-MV Van de Graaff accelerator, and a Co-60 gamma irradiation facility. In addition to nuclear physics, interdisciplinary applied research includes materials studies, radiological science, nuclear engineering and reactor research. It has a strong history of federal funding, with close partnerships with industry and national labs.



Detector development research on campus with industry collaboration

The Nuclear Physics Research Group:

The group carries out fundamental research in experimental nuclear physics and astrophysics, and applied research in detector development and instrumentation, funded by the U.S. Department of Energy. Topics include precise electromagnetic rates in light nuclei, isomers and collective excitations in the heaviest nuclei, waiting-point nuclei along the proton drip-line, beta decay of neutron-rich fission fragments, segmented gamma-ray detectors, proton micro beams, and dual neutron-gamma scintillators.

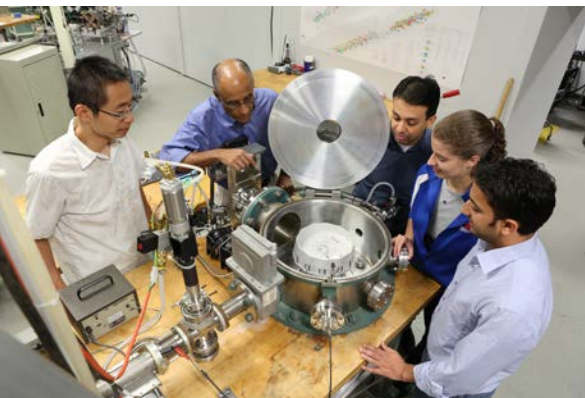

Scattering chamber for particle irradiation

Graduate Studies in Physics:

Ph.D. candidates receive full financial support. TA/RA appointments include full waiver of tuition and fees and 80% of health insurance costs. The modest faculty size, coupled with a high commitment to research, leads to quality interactions and mentoring of graduate students.

www.uml.edu/Physics

www.uml.edu/Research/Nuclear-Physics

Graduate Studies in Nuclear Physics at **University of Michigan**



Nuclear People:

| | |
|-----------------------|----|
| Experimental Faculty: | 4 |
| Theoretical Faculty: | 0 |
| Postdoctoral Fellows: | 6 |
| Graduate Students: | 15 |

Application deadline:

December 15

Departmental web site:

<http://www.lsa.umich.edu/physics>

Application site:

[lsa.umich.edu/physics/
/graduate-students/application.html](http://lsa.umich.edu/physics/graduate-students/application.html)

Contact for Nuclear Science:

Wolfgang Lorenzon
(734) 647-6825
lorenzonz@umich.edu



General Info:

The University of Michigan, founded in 1817, is a leader in undergraduate and graduate education. The university is one of the world's premier research universities encompassing world renowned faculty, rigorous academic programs and diverse cultural and social opportunities in a stimulating intellectual environment.

Research spending at the University of Michigan is above \$1.3 billion which highlights the university's role as an economic resource benefitting the entire state.

The U-M consistently ranks among the nation's top five research universities, based on R&D expenditure statistics compiled by the National Science Foundation.

Nuclear physics research areas:

Hadronic Structure of Nucleons
Spin-Momentum Correlations in QCD
Tests of Fundamental Symmetries
Nuclear Detector Development

Other broad research areas in department:

Astrophysics / Cosmology
Atomic, Molecular & Optical
Biophysics / Biomedical Physics
Condensed Matter Physics
Elementary Particle Physics

University of Michigan: Research in Nuclear Science

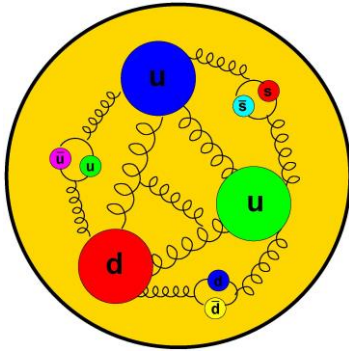

Hadronic Structure and Dynamics of Partons:

Professor Aidala's and Lorenzon's research focuses on understanding the quark-gluon structure of the nucleons. Current studies are carried out at Fermilab as part of the SeaQuest experiment to determine the antiquark distribution in the nucleon sea. At BNL Professor Aidala also studies spin-momentum correlations in the nucleon as part of the PHENIX experiment at the Relativistic Heavy Ion Collider.

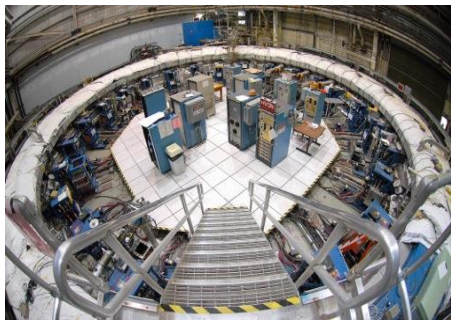

Tests of Fundamental Symmetries:

Professor Chupp's group pursues development of precision measurement, optical pumping, and nuclear polarization techniques for application to a variety of fundamental and applied problems. Professor Chupp is leading searches for the CP-violating electric dipole moments of heavy atoms (RadonEDM Experiment), and the neutron as well as the muon magnetic moment $g-2$ experiment at Fermilab.

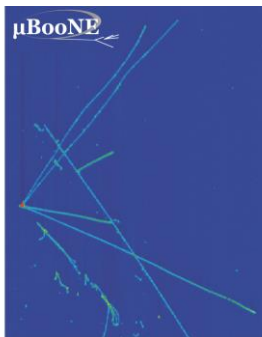

Neutrinos as a Probe of the Nucleus:

Professor Spitz's group studies the neutrino and its role in the evolution of the Universe. The key to this research, centered around neutrino mass and mixing, is developing a detailed understanding of how the neutrino interacts with the nucleonic structure of the nucleus. To this end, the Spitz group collaborates on the MicroBooNE and SBND experiments at Fermilab and the JSNS2 experiment at JPARC in Japan.

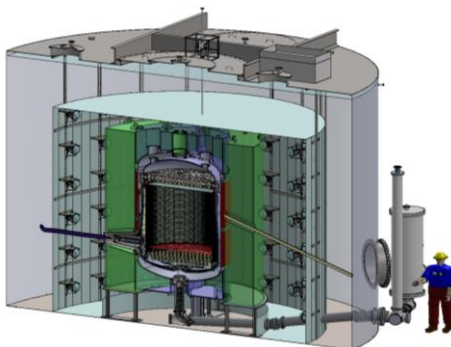

Dark Matter Detection:

Professor Lorenzon is involved in a liquid xenon based Dark Matter experiment, LZ, at the SURF laboratory in South Dakota. The lab provides an ideal environment for ultra-low background experiments and is well suited to detect WIMPS through their interactions with atomic nuclei. Direct detection of dark matter would have a profound impact not only on nuclear physics, but also on cosmology, astronomy and particle physics.

PERSONNEL

| | |
|-----------------------------|----|
| Experimental faculty | 25 |
| Theoretical faculty | 15 |
| Accelerator physics faculty | 12 |
| Graduate students | 78 |
| Female faculty | 5 |
| Female graduate students | 24 |
| Minority graduate students | 5 |

RANKING

Graduate programs
in nuclear physics
U.S. News & World Report

#1



RESEARCH

Accelerator physics
Fundamental interactions
Nuclear astrophysics
Nuclear reactions
Nuclear structure

Other research areas in department

Astronomy and astrophysics
Condensed matter physics
Elementary particle physics

CONTACT

NSCL Associate Director for Education

Artemis Spyrou
517-908-7141
spyrou@nscl.msu.edu
www.nscl.msu.edu

Department website
www.pa.msu.edu

General university, department, and
admissions information
www.gradschoolshopper.com

Online application

Applications due by January 1 to
be considered for fellowships.
Spring admission is possible.
www.pa.msu.edu/grad

Graduate brochure

[http://nscl.msu.edu/researchers/
graduate/Brochure.html](http://nscl.msu.edu/researchers/graduate/Brochure.html)

MSU's commitment to nuclear physics extends back over 50 years. Today the university has achieved international renown for its contributions in the fields of nuclear structure, nuclear astrophysics, heavy-ion reaction mechanisms, accelerator physics, beam dynamics and experimental techniques.

MSU awards 10% of the nation's nuclear science doctorates

Located on campus, the National Superconducting Cyclotron Laboratory (NSCL) is the leading rare isotope research facility in the United States. The NSCL/FRIB users organization has over 1300 members. NSCL researchers employ a wide range of tools for conducting advanced research in fundamental nuclear science, nuclear astrophysics, and accelerator physics. Funded primarily by the National Science Foundation and MSU, NSCL currently operates two superconducting cyclotrons: the K500 was the first cyclotron to use superconducting magnets, and the K1200 is the highest-energy continuous beam accelerator in the world.

MSU has the largest campus-based nuclear science facility in the world

MSU students at NSCL/FRIB have outstanding opportunities to pursue research at a national laboratory within a major research university:

- Under the guidance of world-renowned faculty, graduate students in experimental nuclear science are involved with all aspects of performing novel experiments: writing a proposal, designing, testing detectors and electronics, analyzing data and interpreting results.
- Graduate students in theory work with local and visiting world experts in the development of fore-front approaches for nuclear theory and astrophysics, including high-performance computation.
- Graduate students in accelerator physics can work on the development of new techniques and equipment that are implemented in the daily operations of accelerators at NSCL and that are important for the development of new accelerators, including for FRIB.





Lines of research at NSCL

NSCL hosts 59 faculty members studying a wide array of topics within the broad realm of nuclear physics. The laboratory can produce a large variety of nuclei, including those with extreme proton-to-neutron ratios, which leads to experiments in the structure of, the forces within, and the decay of rare isotopes. Faculty use results to study astrophysical phenomena such as the mechanisms behind supernovae and the creation of elements, and the interplay of strong/weak/EM forces as a test of fundamental symmetries. The laboratory also claims strong expertise in accelerator physics and engineering, pushing the boundaries of ion sources, production targets, cryogenics and linear accelerators.



Center for the Evolution of the Elements

MSU is one of the core institutions of the JINA Center for the Evolution of the elements, a NSF Physics Frontiers Center. JINA-CEE offers unique opportunities for graduate students to learn and work at the intersection of nuclear physics and astrophysics, and connect with JINA-CEE partners elsewhere in the US and at partner institutions across the world. JINA-CEE offers research and training opportunities in nuclear experiment, nuclear theory, astrophysics theory, and observations. You can become part of JINA-CEE by joining either the nuclear science or the astronomy graduate program at any of the JINA-CEE institutions. jinaweb.org



Facility for Rare Isotope Beams

The U.S. Department of Energy recognized MSU's excellence and impact in nuclear science by selecting the university to design and establish the Facility for Rare Isotope Beams—a \$730 million laboratory that will lead the world in advancing the understanding of rare nuclear isotopes. FRIB will fuel breakthrough applications as it provides research opportunities for scientists and students from around the globe. Design efforts and construction continue towards desired operation by 2022. frib.msu.edu



More on Michigan State University

The nation's pioneer land-grant university, MSU was founded in 1855 as a bold experiment. As one of the top research universities in the world and a member of the Association of American Universities, MSU offers nationally ranked and recognized academic, research, and service-learning programs and leads the nation in study abroad among public universities. A diverse and inclusive academic community, in fall 2014 MSU enrolled more than 49,000 students from all 50 states and more than 130 countries, engaged more than 2,000 faculty members, and offered 200 programs of study in 17 degree-granting colleges. msu.edu/admissions

Graduate Studies in Nuclear Physics



Research Group People:

| | |
|---------------------------|-----|
| Theoretical Faculty: | 3 |
| Postdoctoral Researchers: | 1-2 |
| Graduate Students: | 12 |

School of Physics and Astronomy:

| | |
|------------------------|-----|
| Physics faculty: | 44 |
| Astrophysics faculty: | 10 |
| Physics grad students: | 140 |

Application deadlines:

January 15
December 15 for international applicants and fellowship candidates

University web site:

www.umn.edu

Departmental web site:

www.physics.umn.edu

Application web site:

www.physics.umn.edu/grad/application.html

Contacts in research group:

Professor Joseph Kapusta
kapusta@physics.umn.edu

Professor Yong Qian
qian@physics.umn.edu

General Information:

The University of Minnesota, Twin Cities, is one of the largest public research universities in the country. The university was founded in 1851, before Minnesota became a state. The Mississippi River runs through the Minneapolis campus with beautiful views of the city skyline.

First year physics graduate students typically take classical mechanics, electrodynamics, quantum mechanics, and thermal/statistical physics. Second and subsequent years are devoted to more specialized courses which, for nuclear theory, may include: advanced quantum mechanics, nuclear physics, particle physics, quantum field theory, general relativity and cosmology, and statistical physics and transport theory.

Graduate students in physics are supported by teaching assistantships, research assistantships, and fellowships.

About the Nuclear Physics Group:

Nuclear theorists at the University of Minnesota seek to understand the properties of dense matter under the conditions present in the early universe, in stars, and during supernovae. Data from experiments which collide nuclei at high energy, such as those at Brookhaven's Relativistic Heavy Ion Collider (RHIC) and soon at CERN's Large Hadron Collider (LHC), can be compared to theoretical calculations and numerical simulations to understand the dynamics of nuclear matter under extreme conditions. Theoretical effort is directed at investigating the nature of these interactions and their implications for understanding quantum chromodynamics (QCD), particularly quark-gluon plasma. Another major thrust is the study of supernova physics, including the explosion mechanism, nucleosynthesis of medium and heavy elements, and neutrino oscillation effects.

Other broad research areas in department:

| | |
|---|-----------------------------|
| Astrophysics, cosmology and gravitation | Elementary particle physics |
| Biological physics | Physics education |
| Condensed matter physics | Space plasma physics |



Joseph Kapusta

researches the properties of matter and radiation at high energy-density using relativistic quantum field theory. He also studies the anti-de Sitter - conformal field theory correspondence arising from D-branes in string theory, and on the thermodynamics of nonlocal field theories arising from string theory. The physical theories of primary interest include QCD, effective hadronic field theories, electroweak theory, and nonlocal field theories arising from or motivated by string theory. The physical environments in which they play a role include high energy nuclear collisions at RHIC and LHC, the early universe, neutron stars, and black holes.

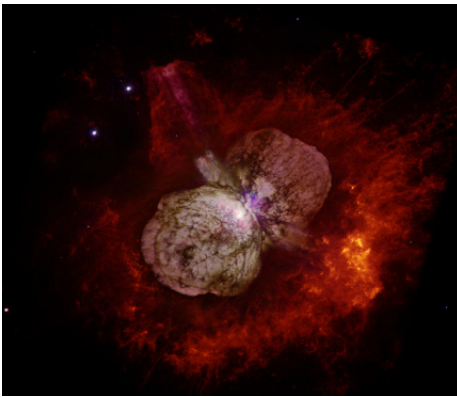

Yong Qian

studies properties of neutrinos, their effects in astrophysical and cosmological environments, the origin of the elements, and chemical evolution of the universe. Supernovae are prodigious sources of neutrinos and provide another venue to study neutrino oscillations. The large neutrino number density near the core of a supernova makes neutrino oscillations extremely sensitive to some unknown parameters thereby allowing possible extraction of these parameters from detection of neutrinos from a future supernova. Neutrinos play important roles in supernova explosion and nucleosynthesis, and these processes can also be affected by neutrino oscillations.

Research group main research areas:

AdS/QCD

Field theories at finite temperature and density

High energy nuclear collisions at RHIC and LHC

Quark-gluon plasma

Neutron stars

Neutrino oscillations in astrophysical environments

Nucleosynthesis in supernovae

Chemical evolution of galaxies

Massive and very massive stars

X-ray and gamma-ray bursts and superbursts

Graduate Studies in Nuclear Physics at



MISSISSIPPI STATE UNIVERSITY



Snap Shot of Nuclear Physics at MSU

Nuclear Physics Faculty : 6 (4 Experiment, 2 Theory)

Graduate Students : 12 (10 PhD, 2 MS)

Median # of Publications : 25 /yr

Median Time for PhD : 5 yrs

Median # of student talks: 10/yr

Website : <http://www.msstate.edu/dept/physics/research/nuclear.php>



Hilbun Hall

Contact in Nuclear Physics:

Dr. Dipangkar Dutta

(662) 325 3105

d.dutta@msstate.edu

Department Website:

www.msstate.edu/dept/physics

Application site:

<http://www.msstate.edu/dept/physics/gradReq.php>

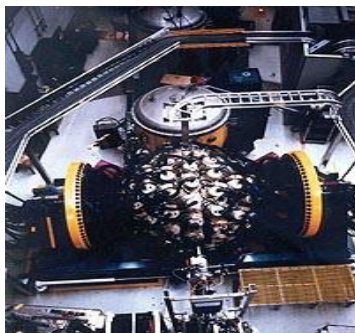

General Info:

Established in 1878 and located in Starkville, Mississippi State is a Land-Grant university featuring the state's only Veterinary Medicine and Architecture program. MSU is a Carnegie Doctoral Research Extensive institution. MSU offers approximately 174 programs through 9 colleges. MSU has a diverse and capable student body and offers a wide range of opportunities for learning and growth.

Away from urban complexities, the MSU campus offers many intellectual, cultural, and recreational advantages. There are frequent intercollegiate athletic events and a variety of recreational opportunities on playing fields and courts, in neighboring forests, and lakes. But major cities such as Birmingham, Jackson, Memphis, and New Orleans are just a few hours drive from campus.

Nuclear Physics Research Areas

Low Energy (Experiment & Theory)

Nuclear Structure

Nuclear Astrophysics

Nuclear Reactions

Intermediate Energy (Experiment)

Nucleon Structure

Fundamental Symmetries

Effective Field Theory

Fundamental Interactions



Graduate Studies in Nuclear Physics at



MISSISSIPPI STATE UNIVERSITY



Nuclear Physics Research at MSU

The nuclear physics faculty at MSU conduct research on a wide range of topics of current interest such as the experimental and theoretical investigations of the structures and decay modes of nuclei in high spin states or far from stability, production and use of radioactive ion beams, experimental and theoretical study of fundamental properties of nucleons and their internal structure in terms of the underlying quark and gluon degrees of freedom of Quantum Chromodynamics (QCD), and, precision tests of fundamental symmetries and the Standard Model in search of “new physics” beyond the standard model. Part of the theoretical effort involves numerical calculations using the super computer on campus and effective field theory. Although most of the experimental research is carried out at national nuclear physics laboratories across the country, experiments are planned, novel detectors and target systems are developed and data analysis are carried out on campus.

Research Facilities and Collaborations

On campus:

High Performance Computational Collaboratory (HPC²)

Medium Energy Physics Detector and Target Lab.

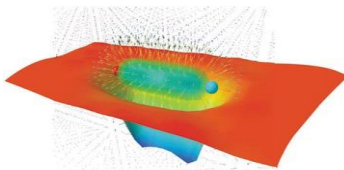

Off campus:

Argonne National Lab, Lawrence Berkeley Lab, Los Alamos National Lab, Jefferson Lab, National Superconducting Cyclotron Lab, Oak Ridge National Lab, Duke University Free Electron Laser Lab



Other Collaborating Institutes (theory):

Technical University of Munich, Aristotle University of Thessaloniki, RIKEN, University of Latvia, University of York

Graduate Studies in Nuclear and Particle Physics at MIT Laboratory for Nuclear Science (LNS)

LNS PEOPLE:

Experimental Faculty: 16
Theoretical Faculty: 13
Graduate Students: 82
Female Faculty: 4

RANKING:

Top Physics program in national and global rankings

APPLICATION SITE:

Web.mit.edu/admissions/graduate

DEADLINE:

December 15, 2016

CONTACT:

Nergis Mavalvala
nergis@mit.edu

Physics-grad@mit.edu

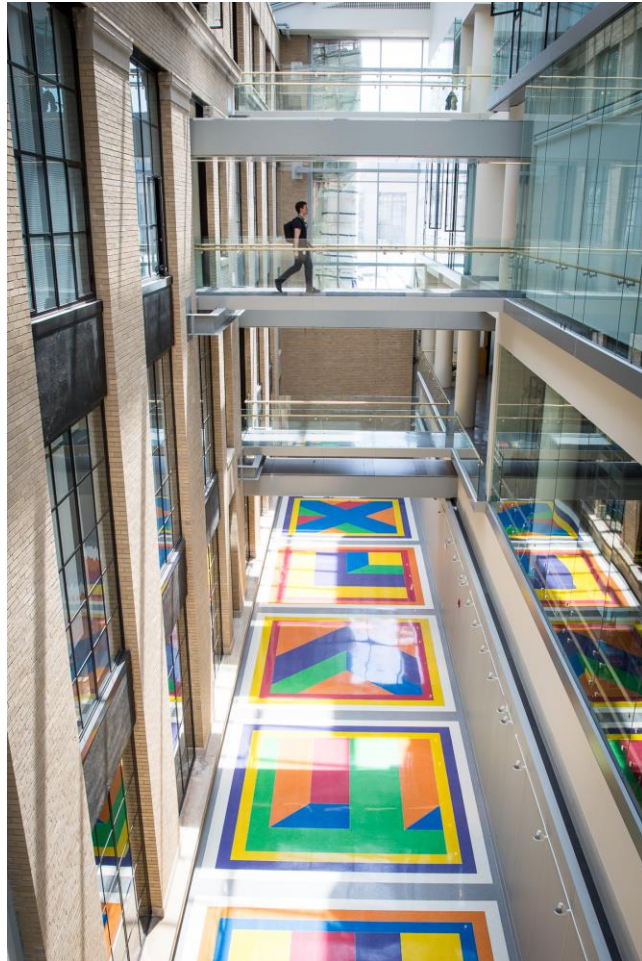

General Information:

At MIT's **Laboratory for Nuclear Science**, we work to understand the structures and interactions of the fundamental constituents of matter. MIT Physics Ph.D. students form the backbone of current LNS research activities worldwide. They carry out research in nuclear and particle physics, subfields that are seamlessly integrated within LNS. Their work is done with large experimental equipment located both at and away from MIT, sophisticated theoretical calculations, state-of-the-art computers, and with guidance and assistance from LNS faculty and highly skilled engineering and technical staff.

LNS students are working to understand how basic properties of the proton, e.g. mass and spin, arise from quarks and gluons. This research involves high energy scattering experiments at the Thomas Jefferson National Accelerator Facility and at other accelerators, theoretical calculations, and large scale computation using the technique of lattice QCD.



With the CMS detector, LNS students explore the phases of systems of quarks and gluons by creating droplets of the hottest matter anywhere in the universe (since it was a few microseconds old) in ultra-relativistic heavy ion collisions at the Large Hadron Collider at CERN in Geneva. Other students use the CMS detector to study proton-proton collisions to measure the properties of the Higgs boson and search for dark matter. Also at the LHC, students use the LHCb detector to study particles containing charm and beauty quarks.

LNS students are developing new theoretical approaches, built upon techniques developed in string theory, to understanding the quark-gluon plasma. They share offices with students applying string theory to questions in quantum gravity and cosmology, with students analyzing jets in proton-proton or heavy ion collisions, with students seeking to predict what Nature will serve at the LHC in addition to the Higgs, and with students devising algorithms for future quantum computers.

Some LNS students are developing ingenious detectors to look for direct evidence of the dark matter that makes up 85% of the mass of the universe; others are busy analyzing data from the Alpha Magnetic Spectrometer that has been operating on the International Space Station since 2011. In particular, they are looking for evidence of dark matter particles annihilating in distant space.

LNS students are working to determine the mass of the electron neutrino and to carefully measure neutrino properties, as well as participating in an experiment to determine whether a neutrino is its own antiparticle. Neutrino efforts include the development of novel high-intensity accelerators to produce neutrinos. In the area of fundamental symmetries, LNS students are attempting to measure the electric dipole moment of the neutron, which may indicate the source of the universe's matter/anti-matter asymmetry.

Other Research Areas within the Department:

Astronomy and astrophysics
Atomic physics
Biophysics
Condensed matter physics
Plasma physics

About Cambridge:

The Boston metropolitan area hosts 51 colleges and universities with 226,000 students, providing an extraordinarily rich intellectual and cultural environment.

Graduate Studies in Nuclear Physics at North Carolina State University

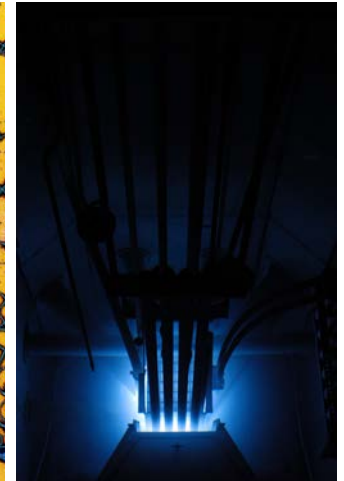
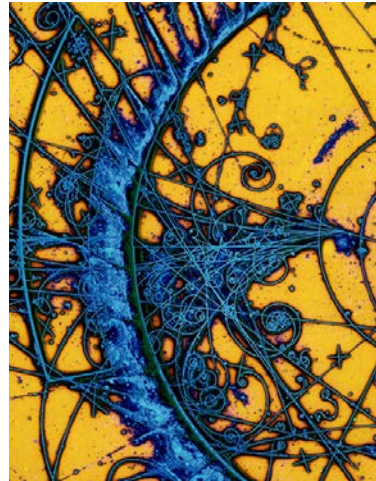

Nuclear People

| | |
|-----------------------|----|
| Experimental Faculty: | 8 |
| Theory Faculty: | 7 |
| Graduate Students: | 30 |

Application Target Date

January 3rd, each year

General University Information

<http://www.ncsu.edu/>

Physics Department Information

<http://www.physics.ncsu.edu/>

Application Information

<http://www.physics.ncsu.edu/graduate>

Contact in Nuclear Physics

Experiment:

Dr. Albert Young
albert_young@ncsu.edu

Theory:

Dr. James Kneller
jim_kneller@ncsu.edu

About NC State, Raleigh, and Research Triangle

With more than 34,000 students and nearly 8,000 faculty and staff, North Carolina State University is a comprehensive university known for its leadership in education and research, and globally recognized for its work in science, technology, engineering and mathematics. NC State faculty generate nearly \$380 million annually in research expenditures and are responsible for 750 patents and 80 start-up companies.

NC State is located in Raleigh, North Carolina, the culturally- and historically-rich capital of the state, and one of the fastest-growing urban centers in America. Raleigh – along with Durham and Chapel Hill – anchor the three corners of the state's Research Triangle region. In the center of the region lies Research Triangle Park, the largest research park in the world and home to industry giants like BD Technologies, Cisco, GlaxoSmithKline, IBM, and Lenovo, as well as the world-renowned Research Triangle Institute.

As the state capital, Raleigh is situated in the heart of North Carolina, a short 2-3 hour drive from both the Blue Ridge Mountains and the Atlantic Ocean. With a vibrant social, sports, cultural and arts scene, multinational business and diverse recreational opportunities, plus a climate that's mild year round, it's easy to see why Raleigh and the surrounding region are consistently rated among the best places to live and work in the United States.

Financial Support

All graduate students in our department are supported by a teaching assistantship (TA), research assistantship (RA), or fellowships. Health insurance is provided to all students in good academic standing. Tuition is also covered for at least 5 years for those with a TA, RA, or fellowship.



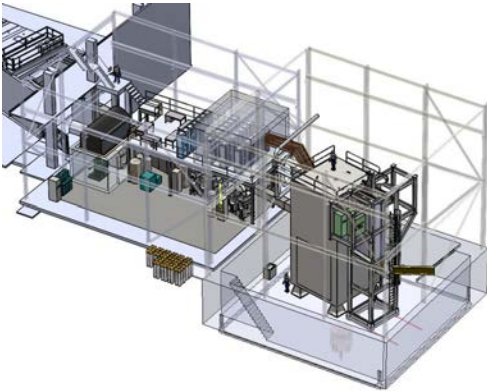

Nuclear Experiment

The experimental nuclear group is active in studies of fundamental symmetries of neutrons and nuclei, neutrino physics, nuclear astrophysics, and applied topics in nuclear structure and nuclear technology. One of the focus areas for the group is experiments which utilize ultracold neutrons, where the NC State group plays a leading role in the neutron static electric dipole moment (nEDM) experiment; in several innovative, high precision measurements of neutron beta-decay (UCNA and the NIST lifetime experiment); and in the development of next generation ultracold neutron sources. We probe the properties of neutrinos by searching for neutrinoless double-beta decay with the MAJORANA DEMONSTRATOR experiment. We also measure astrophysical reactions with the aim of understanding how stars burn their fuel and the origin of the elements.



Our faculty are members of the Triangle Universities Nuclear Laboratory (TUNL), a DOE Center of Excellence which offers a unique suite of low energy, polarized particle beams, the High Intensity Gamma-Ray Source, and cryogenic facilities for local experiments. On the NCSU campus, we also perform research at the PULSTAR reactor, where we are building a world-class ultracold neutron source. Some of our faculty are affiliated with Oak Ridge National Laboratory, and perform research at ORNL's Spallation Neutron Source.

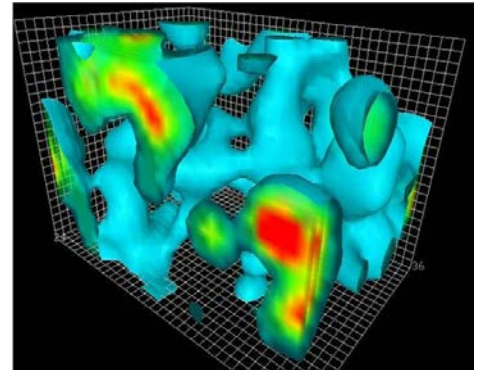

Nuclear Theory

The seven faculty of the theoretical nuclear and particle physics group at NC State investigate a broad range of topics relating to nuclear physics. These include the study of quantum chromodynamics, the quark structure of mesons and baryons, hadronic interactions, hadronic matter under extreme conditions, nuclear structure, photonuclear reactions, heavy ion collisions, cold atomic systems, superfluidity, viscous hydrodynamics, electroweak symmetry breaking, neutrino mixing, neutrino interactions with nucleons and nuclei, stellar evolution, supernovae, nucleosynthesis, the early universe, tests of the standard model, light-front quantization, effective field theory, and non-perturbative lattice methods. We have ties with the nearby Thomas Jefferson National Accelerator Facility, the Joint Institute for Nuclear Astrophysics, and the Facility for Rare Isotope Beams. Funding opportunities from the Southeastern Universities Research Association are available for qualified graduate students. NC State co-hosts the weekly Triangle Universities Nuclear Theory (TNT) seminar series together with Duke and UNC Chapel Hill.

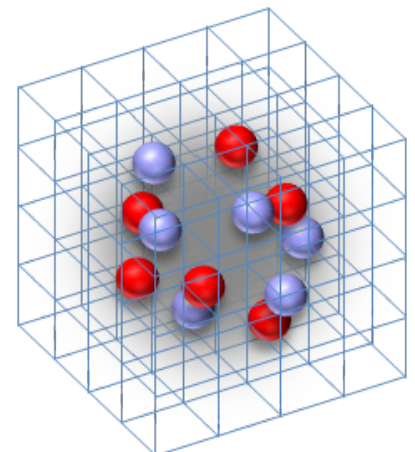

Graduate Studies in Nuclear and Particle Physics at New Mexico State University



Physics People:

| | |
|-------------------------------|----|
| Experimental Nuclear Physics: | 4 |
| Theoretical Nuclear Physics: | 2 |
| Other Faculty: | 11 |
| Graduate Students: | 34 |

Graduate Research Areas:

Nuclear and Particle Physics
Condensed-matter Physics
Geophysics

Application deadlines:

Fall Admission: February 15th

Spring Admission: November 15th
(September 1st for international students)

Departmental web site:

<http://physics.nmsu.edu>

Application site:

<http://gradschool.nmsu.edu>

Contact:

Dr. Michael Engelhardt
graduate-advisor@physics.nmsu.edu

About New Mexico State University:

Located in Las Cruces, NMSU is a comprehensive land-grant institution of higher learning dedicated to teaching, research, and service at the undergraduate and graduate levels. NMSU is a NASA Space Grant College, a Hispanic-serving institution and is home to the very first Honors College in New Mexico. NMSU provides learning opportunities to a diverse population of students and community members at five campuses, a satellite learning center in Albuquerque, cooperative extension offices located in each of New Mexico's 33 counties, 12 research and science centers, and through distance education.

Nuclear Physics Research Areas:

- Experimental Investigation of the Spin Structure of the Nucleon
- Theoretical Studies of the Transverse Nucleon Structure
- Search for Low-Mass Dark Matter in Neutrino Detectors
- Heavy-Flavor Production in pp Collisions
- Exploration of the Nature of Neutrinos
- Computation of Nucleon Structure via Lattice QCD
- Study of Neutrino-Nucleus Interactions

Nuclear and Particle Physics at New Mexico State University:

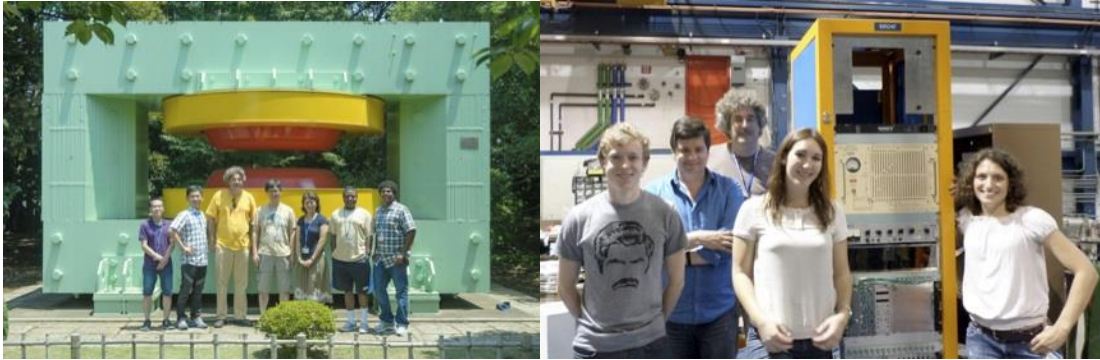

- **Experimental Investigation of the Spin Structure of the Nucleon:** We use the nation's only particle collider facility, the Relativistic Heavy-Ion Collider (RHIC) at Brookhaven National Laboratory, to study the interactions of spin-polarized protons at high energies in order to discover how the constituents of the proton (the quarks and gluons) work together to create the spin-1/2 ground state we observe.
- **Theoretical Studies of the Transverse Nucleon Structure:** We study how the distribution of quarks in the transverse plane relates to other observables and how these connections can be used to create tomographic images of the nucleon. Furthermore, we study what can be learned from various quark-gluon correlations and the role of gluons in the definition of quark orbital angular momentum.
- **Search for Low-Mass Dark Matter in Neutrino Detectors:** Neutrino production facilities and detectors are ideal to search for low-mass dark matter candidates. This type of dark matter search pushes to mass ranges below traditional, deep-underground WIMP searches. We have recently used the MiniBooNE detector for a dedicated dark matter run, and are proposing new runs for the Short Baseline Neutrino detectors at Fermilab.
- **Heavy-Flavor Production in pp Collisions:** We have made better measurements of heavy flavor production with newly upgraded detectors at RHIC. In the polarized proton collisions at RHIC, we use heavy-flavor production to study the contribution of gluons to the longitudinal and transverse spin structure of the proton.
- **Exploration of the Nature of Neutrinos:** At Fermi National Accelerator Laboratory, we are preparing to study neutrino interactions with liquid argon in a large time-projection chamber with the goal of exploring the nature of neutrino oscillations, as well as probing the structure of the nucleon.
- **Computation of Nucleon Structure via Lattice QCD:** Nucleon structure is studied using Lattice QCD, testing QCD in relation to experiment, as well as providing hadronic matrix elements relevant for the analysis of fundamental interactions and searches for physics beyond the Standard Model.
- **Coherent Elastic Neutrino-Nucleus Scattering (CEvNS):** We are part of the COHERENT collaboration to discover CEvNS (neutrino elastic scattering on atomic nuclei) in low-energy-sensitive detectors at the Oak Ridge National Laboratory Spallation Neutron Source. These first measurements will constrain non-standard neutrino interactions and develop a new tool to look for sterile neutrino oscillations.



Department of Physics & Astronomy

Faculty: 35
Graduate Students: ~81
Research Areas: Astronomy, Biophysics,
Condensed Matter, Nuclear Physics,
Particle & Nuclear Astrophysics, and
theoretical Gravitation, Cosmology, HE
Physics

Departmental Website

<http://www.physics.unc.edu/>

Nuclear Physics Research Areas

Experimental Nuclear Astrophysics
Neutrinoless Double Beta Decay
Search for Neutrino Mass
Dark Matter Searches
Nuclear Instrumentation
Applied Nuclear Physics
Many-body dynamics via
Quantum Monte-Carlo &
Density-functional Theory
Fundamental Symmetries
Nucleosynthesis in Supernovae

Nuclear Physics Personnel

Experimental Faculty - 5
Theoretical Faculty - 3
Post-Doctoral Research Associates- 6
Graduate Students - 16

Contact in Nuclear Physics:

Prof. Reyco Henning
rlenning@unc.edu
Phone: (919) 962-1386

Triangle Universities Nuclear Laboratory

The Triangle Universities Nuclear Laboratory (TUNL) is a U.S. Department of Energy (DOE) Center of Excellence that focuses on low-energy nuclear physics research. TUNL is a consortium of three major research universities in the North Carolina Research Triangle Area: Duke University, North Carolina State University, and the University of North Carolina at Chapel Hill. From these three and other collaborating Universities, about 30 faculty members, 20 postdocs and research scientists, and 50 graduate students conduct research at TUNL. UNC faculty lead several experiments at TUNL.

UNC-Chapel Hill

Established in 1789 as the nation's first public university, Carolina is among its best. *U.S. News & World Report's* 2012 "Best Colleges" guidebook named us fifth best public university for the eleventh consecutive year.

The University is located on a 750-acre campus in downtown Chapel Hill, which ranks 10th among the top 100 "Best Places to Live in America" based on a survey of cities with populations between 50,000 and 300,000 by *Money* magazine.

Graduate Application Target Date

December 13, each year

Application website

<http://gradschool.unc.edu/admissions/instructions.html>

Programs and Facilities for Nuclear Physics Research at The University of North Carolina



THE UNIVERSITY
of NORTH CAROLINA
at CHAPEL HILL

Triangle Universities Nuclear Laboratory (TUNL) is one of four Department of Energy Nuclear Physics Centers of Excellence, with affiliated experimental and theoretical faculty from Duke, NC State, and UNC-Chapel Hill. Located on Duke's campus, TUNL draws collaborators worldwide, with opportunities in both accelerator and non-accelerator based research. An important TUNL facility is the High Intensity Gamma Source (HIGS), which provides 1 to 100 MeV γ -ray beams of fluxes $10^8/s$ with energy spreads $\Delta E/E < 3\%$. More than 5% of U.S. nuclear physics PhDs graduate annually from TUNL-related programs.

Experimental Nuclear and Astroparticle Physics. This UNC group (Henning, Wilkerson) is playing a leading role in MAJORANA, an international collaboration searching for neutrinoless double beta decay in ^{76}Ge . The collaboration is currently taking data with the MAJORANA Demonstrator at the Sanford Underground Research Facility in SD and planning the next generation experiment. The group is also involved in the KATRIN tritium beta decay experiment, a direct measurement of neutrino mass. Other activities include experiments to probe fundamental conservation laws and searches for different types of dark matter.



UNC students and postdocs played key roles in the construction of MAJORANA.

The Laboratory for Experimental Nuclear Astrophysics (LENA) (Iliadis, Champagne) at TUNL supports world-class experimental and theoretical research on nuclear reactions and their importance to the evolution of stars and the origin of the elements. It has two low-energy electrostatic accelerators capable of delivering stable, high-intensity charged-particle beams below 1 MeV to a common target. One is an electron-cyclotron-resonance (ECR) source on a 200-kV platform; the other is a 1-MV Van de Graaff accelerator. The former currently holds the world record for average ion beam intensity on target among low-energy nuclear astrophysics laboratories.



Graduate Student Jack Dermigny programming the movable extraction electrode for the new LENA ECR source.

Nuclear Theory. A very active nuclear theory group (Drut, Engel) at UNC focuses on nuclear structure, fundamental symmetries, nuclear astrophysics and general many-body physics, in particular lattice Monte-Carlo methods. Recently the group has (for example) calculated the nuclear matrix elements governing neutrinoless double beta decay, studied viscosity in strongly interacting gases of cold atoms, and modeled nucleosynthesis in stars and supernovae. Several graduate students work on these and related problems.

Nuclear Physics Contact:

Prof. Reyco Henning
rhennin@unc.edu
Phone: (919) 962-1386

Please visit our website for more information: physics.unc.edu/research-pages/nuclear



UNIVERSITY OF NOTRE DAME

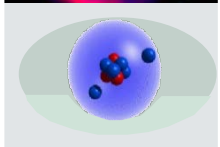
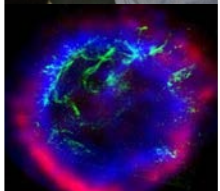
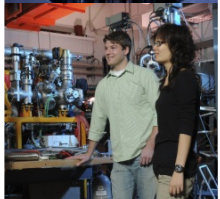
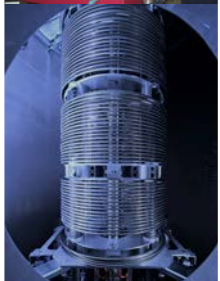
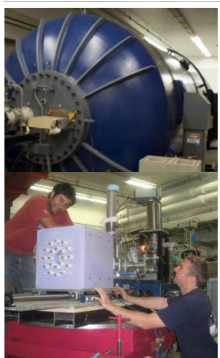

Nuclear Experiment

During its 75 years of history, the Nuclear Science Laboratory at the University of Notre Dame has contributed to all aspects of nuclear physics: to our understanding of a nucleus as a unique few body quantum system; to our interpretation of nuclear reactions and reaction mechanism as signatures of the four fundamental forces governing the cosmos; and finally to the critical role these reactions provide for the synthesis of the chemical elements formed in generations of stars since the beginning of our universe.

St Ana, vertical, single ended accelerator, installed in 2012

10-MV Pelletron accelerator

St George recoil separator

TwinSol, radioactive beam facility

St Andre, 3-MV accelerator, installed in 2016

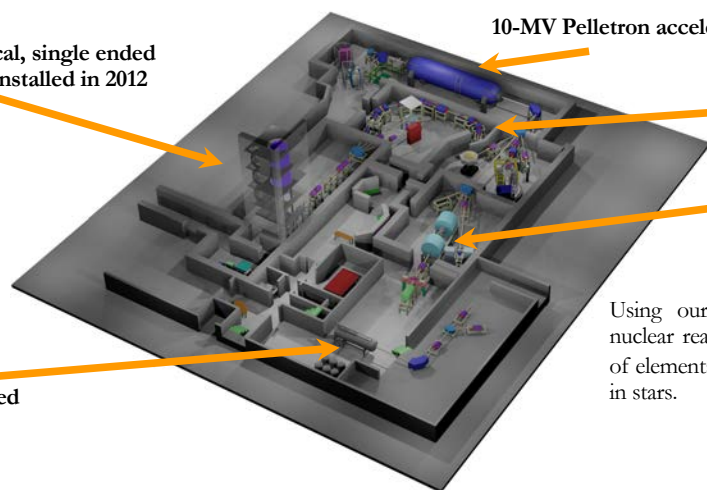

Using our accelerators, we study the nuclear reactions crucial to the synthesis of elements and the generation of energy in stars.

Applied nuclear physics

Recently, our research program has been expanded towards applied nuclear physics. This program encompasses a broad array of experimental measurements at the interface between nuclear or atomic physics methods and materials that impact society. Fundamental techniques that have existed for decades in many cases, are applied in novel environments. These measurements have applications in the determination of lead in paint, or halogenated flame-retardants in furniture, or the occurrence of per- and polyfluorinated compounds in the environment.

CASPAR



CASPAR (Compact Accelerator System for Performing Astrophysical Research) is the first US underground facility for measurements of nuclear fusion reactions relevant for stellar burning. It was built by Notre Dame researchers in collaboration with South Dakota School of Mines and Colorado School of Mines at the Sanford Underground Research Facility (SURF) in Lead, South Dakota, where low cosmic-ray background underground allows for measurements of cross section inaccessible for laboratories on the surface. More information about the research at CASPAR facility can be found at: <https://www.nd.edu/features/caspar/>

Our students

Notre Dame's Nuclear Science Laboratory, one of the few university nuclear accelerator laboratories in the nation, gives both graduate and undergraduate students extensive and invaluable hands-on experience with designing and using experimental equipment. Our students are involved in all steps of research from designing the experiment to operating the accelerators.

The nuclear physics group utilizes not only the local facilities, but is also involved in a variety of experiments at research institutions world-wide.



Nuclear Theory

Nuclear theory research at Notre Dame addresses the origin of the elements and the strongly correlated motion of nucleons within the nucleus, through investigations in theoretical nuclear astrophysics and nuclear structure physics. In nuclear astrophysics, we probe the properties of nuclei and nuclear matter under extremes of temperature and density, in order to constrain nuclear physics, astrophysical environments, and non-standard model physics. In nuclear structure, we seek to understand the emergence of simple patterns, such as quantal rotational and vibrational modes, through ab initio and collective approaches, in nuclei from the very lightest to the heaviest and to the limits of stability.

For more information about the nuclear theory group visit: <http://nuclear-theory.nd.edu>.

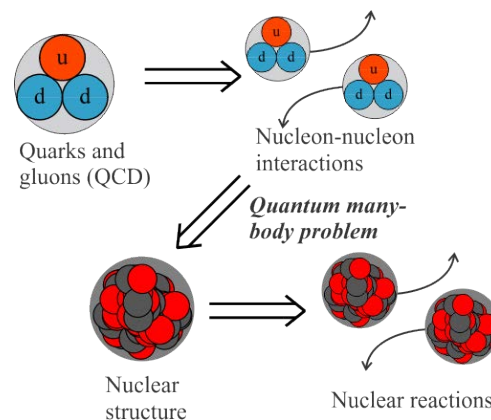

Institute for Structure and Nuclear Astrophysics



ISNAP is a university-based four-accelerator laboratory funded by the National Science Foundation with a broad program in low-energy nuclear physics. Visit us at: www.isnap.nd.edu

Joint Institute for Nuclear Astrophysics - Center for the Evolution of the Elements



Notre Dame is a founding member of the Physics Frontier Center JINA-CEE, an intellectual center with the goal to enable swift communication and stimulating collaborations across field boundaries in nuclear astrophysics and to provide a focal point in a rapidly growing and diversifying field. More information about JINA-CEE: www.jinaweb.org

Physics at Notre Dame

The Department of Physics at Notre Dame is home to over 90 Ph.D. students, working closely with over 40 faculty members in a broad spectrum of research areas.

The University of Notre Dame is consistently ranked among the nation's top 25 institutions of higher education. The university is adjacent to South Bend, Indiana, near the southeast corner of Lake Michigan, and is approximately 90 miles from Chicago.

All admitted students receive full tuition support and a stipend. Beginning doctoral students typically work as teaching assistants (about 15 hours per week) during the academic year. During the summer most students hold research assistantships. The majority of advanced students work as research assistants funded by external research grants. Applicants with strong academic records are automatically considered for fellowships.

The APS cites the Notre Dame Department of Physics as a female-friendly physics department with approximately 30% female graduate students.

Notre Dame offers the research opportunities of a large university coupled with the environment of a smaller, private university. The Notre Dame Department of Physics prides itself on its collaborative and supportive environment.

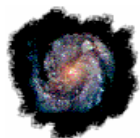

Astrophysics

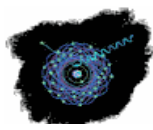

Atomic physics

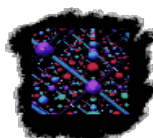

Condensed matter physics / Biophysics

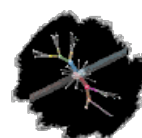

High energy physics

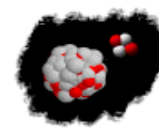

Nuclear physics

How to apply

Detailed information on how to apply to the graduate program can be found at: <http://physics.nd.edu/graduate-program/apply/>.

Contact us

To learn more about our faculty and programs, please contact the nuclear physics group (Prof. Philippe Collon, pcollon@nd.edu, 574-631-3540) or visit the Department's website at <http://physics.nd.edu>.

Graduate Studies in Nuclear Physics at



OHIO
UNIVERSITY



People:

| | |
|----------------------------|----|
| Experimental Faculty: | 10 |
| Theoretical Faculty: | 4 |
| Technical Staff: | 2 |
| Post-doctoral Researchers: | 2 |
| Graduate Students: | 17 |
| Female faculty: | 2 |

Department:

www.ohio.edu/cas/physastro/

Nuclear Physics:

inpp.ohiou.edu

Apply:

www.ohio.edu/cas/physastro/grad/admissions.cfm#ADMISSIONS

Department Admissions Contact:

Dr. Alexander Neiman
(740) 593-1701

Application Deadline:

January 15

Nuclear Physics Contact:

Dr. Daniel Phillips
(740) 593-1698
phillid1@ohio.edu

General Information:

Ohio University was founded in 1804, making it the first university established in Ohio, and the ninth oldest public university in the United States. Today, the enrollment on the Athens campus is approximately 23,700 students, of which about 4,000 are graduate students. Ohio University is made up of 11 colleges. Nuclear Physics studies take place within the Department of Physics and Astronomy, in the College of Arts and Sciences. The main campus is located in Athens, Ohio, along the scenic Hocking River in the southeastern part of the state.

Nuclear Physics Research Areas:

Nuclear Astrophysics
Nuclear Structure and Reactions
Relativistic Heavy Ions
Baryon and Meson Spectroscopy
Parity-Violating Electron Scattering
Internal Structure of the Nucleon
Applications of Nuclear Physics
Few-Body Systems
Effective Field Theory
Halo and Exotic Nuclei
Neutron Star Physics

Other Broad Research Areas in Department:

Condensed Matter Physics
Astronomy and Astrophysics
Biophysics

Ohio University



Institute of Nuclear and Particle Physics:

The Institute of Nuclear and Particle Physics was established at Ohio University in 1991 to bring coherence to the several successful but diverse nuclear and particle physics activities taking place within the Department of Physics and Astronomy, and to coordinate the activities of both theoretical and experimental subatomic physics.

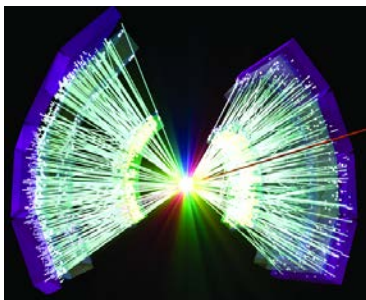

Experimental Nuclear Physics Research:

This area covers low-energy experiments on nuclear astrophysics, nuclear structure and reactions, and applied nuclear physics; medium-energy experiments to study the structure of the nucleon and quark dynamics; and experiments with relativistic heavy ions to study nuclear matter under extreme conditions. These experiments are carried out at facilities around the world.

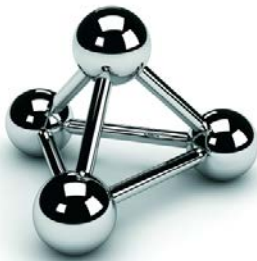

Theoretical Nuclear Physics Research:

Theoretical research explores the manifestations of strong-interaction dynamics in terrestrial experiments and astrophysical phenomena. Some examples are: (a) the chiral structure of the nucleon, electron scattering, and three-body scattering, (b) reactions involving nuclei near the neutron- and proton-drip lines, (c) neutron star structure, and (d) transport properties of hadronic matter.



Edwards Accelerator Laboratory:

Faculty and students perform some of their experiments at the Edwards Accelerator Laboratory on the Athens campus. It includes a 4.5-MV Van de Graaff accelerator with multiple ion sources, beamlines, and experimental areas for research in nuclear astrophysics, nuclear structure, and applications. For a complete description of facility equipment and capabilities, visit: inpp.ohiou.edu/~oual/.

Graduate Studies in Nuclear Physics at Ohio State University (OSU)

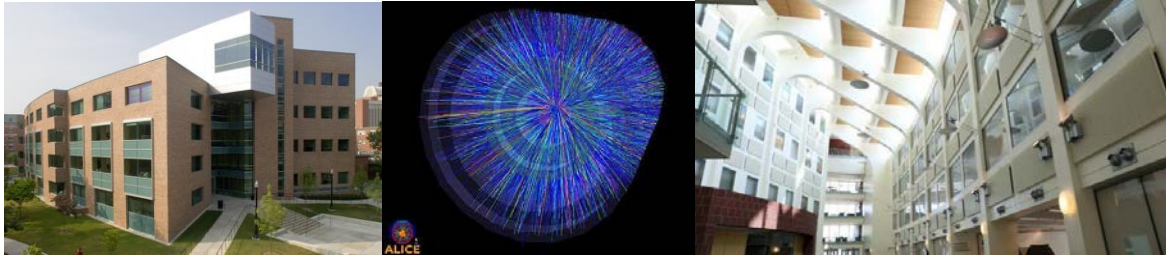

Nuclear People:

Faculty: 7
Postdocs: 5
Graduate Students: 12

Other Graduate Research Areas:

AMO Physics, Biophysics, Cold Atoms, Condensed Matter Physics, Cosmology and Astro-Particle Physics, High Energy Physics, and Physics Education

Application deadline:

*Dec. 13 for domestic applicants;
Nov. 30 for international applicants.*

Departmental web site:

physics.osu.edu

Application site:

physics.osu.edu/graduate-admissions-application

Contacts for Nuclear Physics:

Mike Lisa (experiment)
614-292-8524
lisa.1@osu.edu
www.physics.ohio-state.edu/~lisa/

Dick Furnstahl (theory)
614-292-4830
furnstahl.1@osu.edu
www.physics.ohio-state.edu/~furnstah/

About OSU:

The university's main campus is one of America's largest and most comprehensive. Ohio's best and a top-20 public university, Ohio State is further recognized by a top-rated academic medical center and a premier cancer hospital and research center. Founded as a land-grant university, OSU has campuses and research centers located around Ohio.

Nuclear Physics Research at OSU:

Nuclear physicists at OSU study a broad range of problems involving the strong interaction. This research includes the direct study of quantum chromodynamics (QCD), the relativistic field theory of quarks and gluons, the connection of QCD to effective theories at low energies, and the manifestation of QCD in the highly compressed and excited nuclear matter created in relativistic heavy-ion collisions.

Effective field theory (EFT) and renormalization group (RG) methods are used by group members to quantitatively explain how low-energy nuclear phenomenology emerges from QCD. These methods enable systematic and model-independent calculations with error estimates, using control over the degrees of freedom to optimize convergence.

At very high densities and temperatures, QCD predicts that strongly interacting matter turns into a quark-gluon plasma (QGP). This QGP can be created in relativistic heavy-ion collisions, and group members are among the leaders in experimental efforts at RHIC and the LHC and in developing theoretical descriptions for the creation, thermalization, and collective dynamical evolution of the QGP.

In high-energy proton or nuclear collisions, the density of gluons is very high and is predicted to reach an interesting new regime called parton saturation. The OSU group is highly active in [plans](#) for an [Electron-Ion Collider](#) (EIC) to discover this phenomenon, and to explore how the proton spin is distributed among its quarks and gluons.

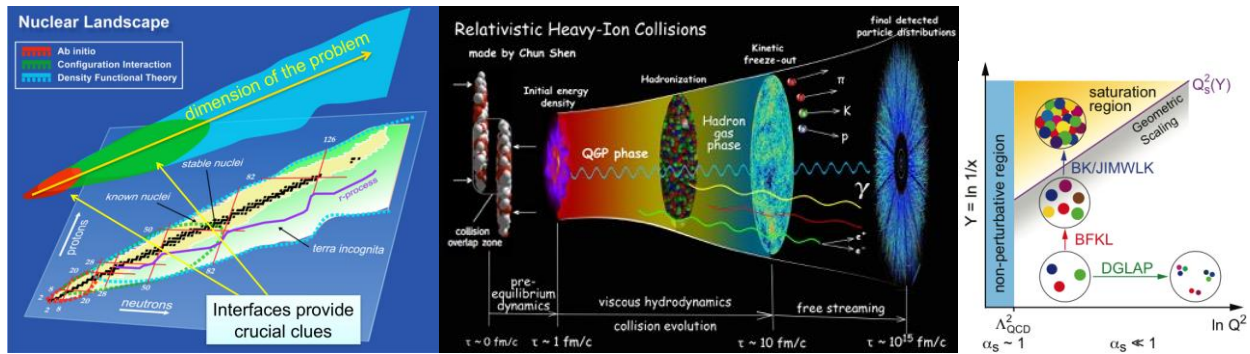

Nuclear Faculty at OSU:

- **Prof. Richard Furnstahl** — Effective field theory and renormalization group methods for nuclear systems; FRIB science; QCD and nuclear phenomena; microscopic nuclear density functional theory; computational many-body methods; Bayesian uncertainty quantification.
- **Prof. Ulrich Heinz** — Phenomenology of particle production in relativistic heavy-ion collisions; thermal quantum field theory in and out of equilibrium; relativistic kinetic theory and relativistic (viscous) hydrodynamics; creation, thermalization, and dynamics of quark-gluon plasma.
- **Prof. Thomas Humanic** — Relativistic Heavy-Ion Collisions; CERN LHC ALICE experiment; boson interferometry; extra-dimensional physics; collision model calculations.
- **Prof. Sabine Jeschonnek** — Investigating matter with electromagnetic probes: electron scattering from few-body systems, in particular from the deuteron; short-range structures in few-body systems; quark-hadron duality.
- **Prof. Yuri Kovchegov** — QCD at high energy and high parton density; heavy-ion collisions and deep-inelastic scattering; applications of string theory to QCD; spin structure of the proton.
- **Prof. Michael Lisa** — Experimental study of relativistic heavy-ion collisions at STAR/RHIC and ALICE LHC; two-particle intensity interferometry, a.k.a. femtoscopy; collective response at ultra-high energy densities and pressure; exploration of the phase diagram of QCD.
- **Prof. Robert Perry** — Quantum chromodynamics; light-front field theory; renormalization group and effective field theory.

About Columbus, Ohio:

Ohio's capital is a friendly city of sleek, modern high-rises and century-old buildings along the banks of the Scioto River. In addition to being home to one of the [finest universities in the nation](#), its attractions range from a rich visual and performing arts scene to a renowned zoo, exciting sports, fine restaurants, and enough specialty shops, outlets, and malls to satisfy even the most avid of browsers and buyers. Find out more about places and things to do in [Columbus](#).



**Graduate Studies
in Nuclear and Particle Physics**



Nuclear Physics Group:

| | |
|-------------------------------|----------|
| Experimental Faculty: | 6 |
| Theoretical Faculty: | 5 |
| <u>Female Faculty:</u> | <u>1</u> |
| Jefferson Lab Professors: | 3 |
| Postdoctoral Researchers: | 4 |
| Graduate Students: | 20 |
| Female Graduate students: | 6 |
| [Accelerator Physics Faculty: | 5+3] |

Fellows of the APS:

7 in Nuclear Physics, 13 total

Application deadline:

January 15th to be fully considered for financial support

General university information:

<http://www.odu.com>

Departmental web site:

<http://sci.odu.edu/physics/>

Application site:

http://sci.odu.edu/physics/graduate/graduate_overview.shtml

For admissions questions, contact Dr. Mark Havey: mhavey@odu.edu

Contact:

Sebastian Kuhn
(757) 683-5804
skuhn@odu.edu

J. Wallace Van Orden
(757) 683-5801
jvanorde@odu.edu

General Information:

Old Dominion University is a state-supported Carnegie Doctoral/Research Extensive institution with more than 24,000 students and over 720 full-time faculty. Norfolk, Virginia is a culturally rich, historic city and a major international maritime center in a metropolitan area of over 1.7 million people. One of seven cities that form the Hampton Roads region, Norfolk is located near the mouth of the Chesapeake Bay in coastal Virginia. Nearby attractions include Virginia Beach, the historical “triangle” of Williamsburg, Yorktown and Jamestown, and many cultural organizations and entertainment venues.

The ODU Physics Department has strong research groups in experimental and theoretical nuclear and particle physics, experimental and theoretical atomic and few-body physics, accelerator physics, theoretical condensed matter physics, and materials science, and offers B.S., M.S. and Ph.D. degrees. The department has 21 tenured or tenure-track faculty and six special appointment Jefferson Lab Professors and is supported by substantial external, peer-reviewed research grants as well as state funds. Thirteen faculty members are APS Fellows. The vibrant program includes about 50 graduate students and more than 80 undergraduate majors.

Nuclear physics research areas:

- The quark structure of matter studied at the nearby Thomas Jefferson National Accelerator Facility (Jefferson Lab, about a half hour drive from ODU) and other international user facilities. www.lions.odu.edu/~gdodge/nucexpt/nucexpt.html
- Theoretical research in high-energy QCD, Lattice QCD, nucleon structure, light nuclei and relativistic dynamics in hadrons and nuclei. ww2.odu.edu/~jdudek/NucTheory/nucltheory.html

Students doing research at Jefferson Lab have all the advantages of working at an international laboratory while being stationed at their home institution.

Old Dominion University continued

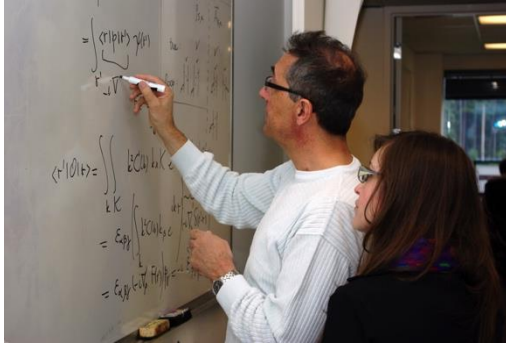

Theoretical Research

The ODU theory group performs research across a broad range of topics in hadronic and nuclear physics, including the electroweak properties of light nuclei, chiral perturbation theory, hadron structure, the properties of nucleons at large energy scales and quantum chromodynamics. This work is of relevance to experiments across the globe, with particular emphasis on experiments performed at the nearby Jefferson Lab. All faculty in the ODU Theory Group are also staff scientists with the Jefferson Lab Theory Group. Graduate students in the group have access to facilities and resources of the Jefferson Lab Theory Center.

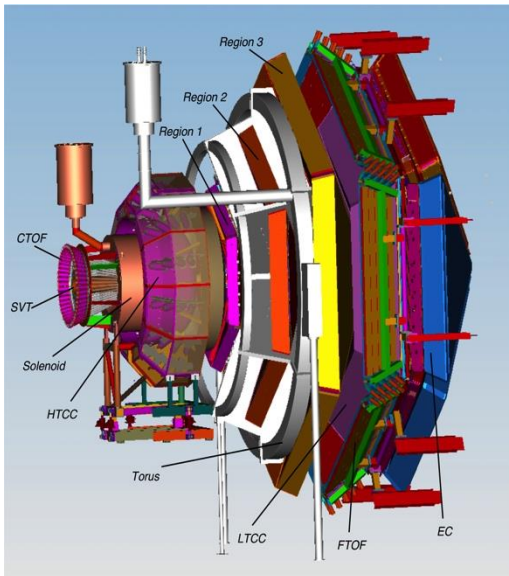

Experimental Research at Jefferson Lab

As one of the largest University groups working at Jefferson Lab, the ODU experimental nuclear physics group leads experiments on the form factors and quark-gluon structure of the nucleon, on studies of meson spectroscopy and decays, on the role of short-range correlations in nuclear structure and on searches for new physics. We helped formulate the Jefferson Lab research program for its (nearly completed) upgrade to 12 GeV beam energy, are building major detectors and other equipment for this program, and are actively planning the next generation facility, the electron-ion collider. The group typically receives about \$1M funding per year from various sources, mainly from the US Department of Energy.



Facilities at Old Dominion University

The experimental nuclear physics group has 5000 square feet of laboratory space, including a **high high-bay** area in the Physical Sciences Building II, which also contains offices for faculty, postdocs and students. The group maintains a LINUX farm for physics analysis and simulation. Standard laboratory equipment and infrastructure allows construction of large detectors for research (e.g. the Region 2 Drift Chambers for the CLAS12 spectrometer at Jefferson Lab, see image to the left). A full-time technician and three postdoctoral researchers are part of the group.

Synergistic research: Center for Accelerator Science - www.odu.edu/sci/research/cas

Graduate Studies in Nuclear Physics at Purdue University



PURDUE
UNIVERSITY™

Nuclear People:

| | |
|-----------------------|---|
| Experimental Faculty: | 3 |
| Theoretical Faculty: | 1 |
| Postdoctoral fellow: | 2 |
| Graduate Students: | 8 |

General Info:

Purdue University was founded in 1869. Today, the West Lafayette campus has an enrollment of approximately 39,000 students, of which about 8,000 are graduate students. The University is comprised of 10 colleges and schools. Purdue's president is Mitch Daniels, former governor of Indiana.

Application deadline:

February 1

Application site:

www.gradschool.purdue.edu/Admissions

General university, department, and admissions information:

www.physics.purdue.edu/academic_programs/graduate
www.physics.purdue.edu

Nuclear physics web site:

www.physics.purdue.edu/henp

Contact in Nuclear Physics:

Fuqiang Wang
(765) 494-5510
fqwang@purdue.edu

Nuclear physics research areas:

High Energy Nuclear Physics
Relativistic Heavy Ion Collisions
Quantum Chromodynamics (QCD)
Nuclear Physics Phenomenology

Other broad research areas in department:

Accelerator Mass Spectrometry
Applied Physics
Astrophysics & Particle/Astrophysics
Atomic, Molecular, and Optical Physics
Biological Physics
Condensed Matter Physics
Elementary Particle Physics
Geophysics

Relativistic Heavy Ion Collisions: The picture to the left depicts a gold-gold collision

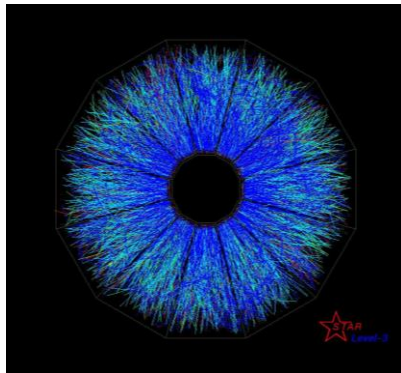

recorded by the STAR (Solenoidal Tracker At RHIC) experiment. The STAR detector is located at the Relativistic Heavy Ion Collider (RHIC, picture to the right), at Brookhaven National Laboratory, Long Island, New York, and gathers data from heavy ion collisions at

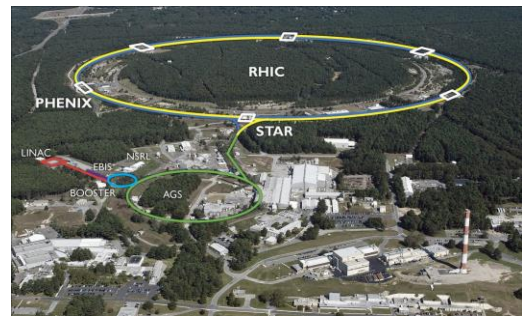

relativistic speeds. Besides STAR, Purdue nuclear physicists also collaborate on the CMS (Compact Muon Solenoid) experiment at the Large Hadron Collider at CERN (The European Organization for Nuclear Research, picture to the right), Geneva, Switzerland. The main objective of these experiments is to study the characteristics of the matter produced in these collisions, particularly the quark-gluon plasma (QGP), which is believed to have existed for a few microseconds in the infant universe after the “Big Bang.”

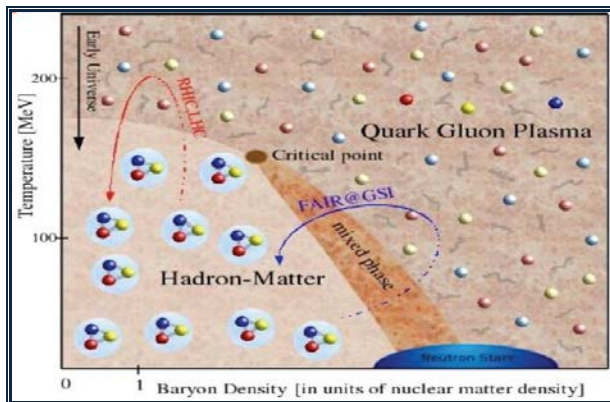
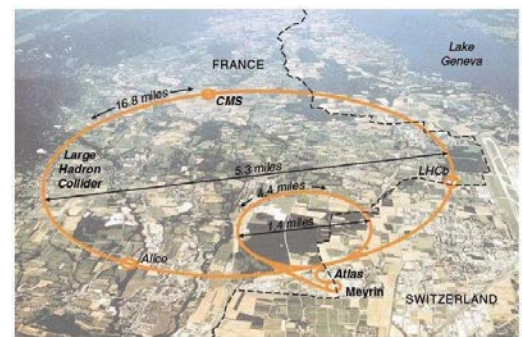

The Phase Diagram of Nuclear Matter:

Scientists expect the QGP to form in relativistic heavy ion collisions. Like water, the nuclear matter can experience phase transitions. Ground state normal nuclear matter resides at (1, 0) on the phase diagram. The red trajectory depicts a path taken by the system following a relativistic heavy ion collision. The blue trajectory corresponds to a low energy collision. QGP may exist in the core of today’s neutron stars.



About West Lafayette:

Purdue University is located in West Lafayette, Indiana, two hours from Chicago, and one hour from Indianapolis. The combined population of West Lafayette and Lafayette is about 100,000. The community offers a unique combination of small town affordability and big city sophistication. Numerous local and nearby state parks provide ample opportunities for outdoor excitement.



UNIVERSITY OF SOUTH CAROLINA

Department of Physics and Astronomy

Physics and Astronomy:

| | |
|--------------------------------|----|
| Astronomy Faculty: | 2 |
| Condensed Matter Faculty: | 8 |
| Nuclear Faculty: | 4 |
| Particles and Field Faculty: | 8 |
| Theoretical and Other Faculty: | 4 |
| Graduate Students: | 49 |
| Female Faculty: | 3 |
| Female Graduate Students: | 13 |

Nuclear Physics:

| | |
|----------------------------|------|
| Graduate Students: | 12 |
| Employment Rate after PhD: | 100% |

Employment Type:

| | |
|---------------------------|-----|
| Nuclear Physics Research: | 70% |
| Education & Industry | 30% |

Application Deadlines:

March 1 (Fall), November 15 (Spring)

Department Website:

www.physics.sc.edu

Application Site:

www.gradschool.sc.edu

Contact in Nuclear Physics:

Ralf Gothe
(803) 777-9025
gothe@sc.edu

General Information:

The University of South Carolina is home to more than 200 years of history and tradition, rising from a single building in 1805 on what would become the heart of the campus, the horseshoe. The University is expanding in support of its research initiatives in nanotechnology, health sciences, future fuels, the environment, and information and knowledge technologies.

Joining the flagship campus in Columbia are four-year campuses in Aiken, Beaufort, and Upstate. Four two-year campuses in Lancaster, Salkehatchie, Sumter, and Union help the University to cover the state.

In addition, the University of South Carolina's Columbia campus has over 325 degree programs through its 16 degree-granting colleges and schools. Students have won 786 national awards totaling more than \$24 million dollars since 1994.

The on-campus enrollment at University of South Carolina for the 2016 Fall Semester was approximately 34,000, including over 8,500 graduate and professional students.

Highlights:

- South Carolina is a part of a select group of public universities listed by the Carnegie Foundation in their highest tier of research institutions in the United States.
- US News & World Report cites USC for its student-enrichment offerings, noting that it has one of the nation's best programs for First Year Experience and Learning Communities.
- USC's Honors College is now ranked number one in the nation and is known for its high-achieving students who earn an average SAT score of 1430.

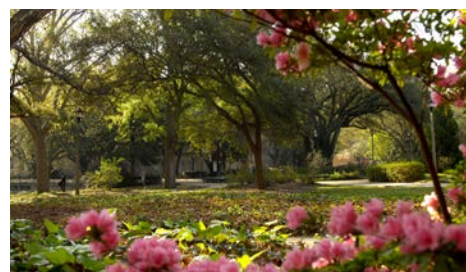

Nuclear Physics at USC:

One of the fundamental forces in nature, described by Quantum Chromodynamics (QCD), arises from the strong interaction between the building blocks of hadrons, the quarks. Gluons exchanged between quarks are the gauge bosons mediating this interaction. The interest in strong interaction stems not only from the fact that it is responsible for the existence of atomic nuclei, and therefore of ordinary matter, but also because its properties are so very different from the properties of the better-known electro-weak force.

There are two experimentally verified perturbative quantum field theories that describe nuclear phenomena: perturbative Quantum Chromodynamics (pQCD) at small distances which is governed by quark and gluon fields; and Chiral Perturbation Theory (ChPT) at larger distances which is governed by pion and nucleon fields. The non-abelian nature of QCD gives rise to a non-perturbative “confinement regime” at intermediate distances where more than 98% of the mass of normal matter is generated.



About Columbia:

South Carolina's premier research university is centrally located in Columbia, the state's capital and largest city. As such Columbia offers a wealth of cultural, intellectual, and recreational opportunities. Residents enjoy a nationally ranked zoo & botanical garden, an award-winning library system, two major arts & entertainment districts, and a cultural scene replete with a world-class art museum, six professional dance companies, and three professional theaters. Columbia consistently ranks among the most livable and affordable mid-sized cities.



The main research theme in **Nuclear Theory** at USC is to study hadrons and their aggregates such as nuclei and even neutron stars. Currently, a main thrust of the group's research is directed to the application of chiral perturbation theory to nuclear systems with the view to giving accurate predictions for various hadronic, electromagnetic, and weak-interaction processes.

The research carried out by the **Experimental Nuclear Physics Group** at USC aims at improving our understanding of Quantum Chromodynamics in the confinement regime and of nuclei in terms of quarks and gluons. The group's activities are concentrated on baryon structure and spectroscopy, baryon interactions, the proton-radius puzzle through the MUSE experiment, and in-medium modifications of hadronic properties as well as on large detector construction. The research program of the group is carried out at the Continuous Electron Beam Accelerator Facility (CEBAF) located at the Thomas Jefferson National Accelerator Laboratory (JLab), the J-PARC proton accelerator in Japan, the electron accelerator MAMI in Mainz, Germany, and the Paul Scherrer Institute (PSI) in Switzerland.



Graduate Studies in Nuclear Physics at Stony Brook University



Nuclear People:

| | |
|-----------------------------------|----|
| Experimental Faculty*: | 12 |
| Theoretical Faculty: | 7 |
| Accelerator Physics Faculty: | 5 |
| Graduate Students: | 22 |
| Female faculty: | 3 |
| Female graduate students: | 4 |
| *(faculty totals include adjunct) | |

Rankings :

#4 Graduate Nuclear Physics program, U.S. News & World Report

Application deadline:

January 15

General university, department, and admissions information:

graduate.physics.sunysb.edu/application

Departmental web site:

www.physics.sunysb.edu

Application site:

app.applyyourself.com/?id=sunysb-gs

Contact:

Barbara V. Jacak
(631) 632-6041
Barbara.Jacak@stonybrook.edu
www.physics.stonybrook.edu

General Info:

From its beginnings a half-century ago, Stony Brook University has been characterized by innovation, energy and progress, transforming the lives of people who earn degrees, work and make groundbreaking discoveries here. A dramatic trajectory of growth has turned what was once a small teacher preparation college into an internationally recognized research institution that is changing the world.

Stony Brook's reach extends from its 1,039-acre campus on Long Island's North Shore—encompassing the main academic areas, an 8,300-seat stadium and sports complex and Stony Brook Medicine—to Stony Brook Manhattan, a Research and Development Park, four business incubators including one at Calverton, New York, and the Stony Brook Southampton campus on Long Island's East End. Stony Brook also co-manages Brookhaven National Laboratory.

And Stony Brook is still growing. To the students, the scholars, the health professionals, the entrepreneurs and all the valued members who make up the vibrant Stony Brook community, this is a not only a great local and national university, but one that is making an impact on a global scale.

Nuclear physics research areas:

| | |
|----------------------|--------------------------------|
| Accelerator physics | Relativistic Heavy Ion Physics |
| Nuclear astrophysics | Cosmic Neutrinos @ Ice Cube |
| Nucleon Spin | |

Other broad research areas in department:

| | |
|--|--------------------------|
| Astronomy and astrophysics | Atmospheric Physics |
| Atomic Molecular Optics | Condensed matter physics |
| Elementary particle physics | Physical Biology |
| Physics Education | Yang Inst. Theo. Phys. |
| Simons Center for Geometry and Physics | |

Stony Brook University

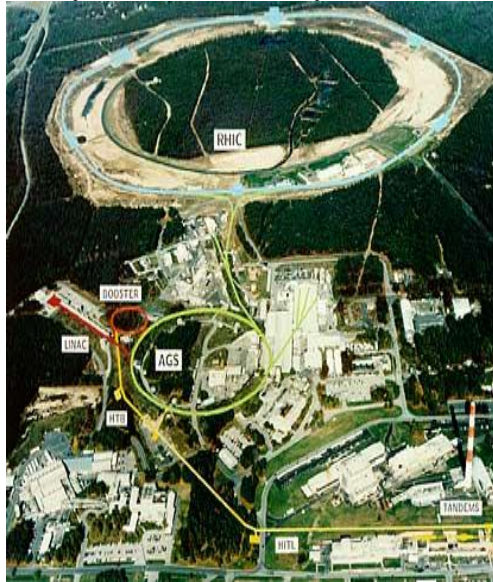

PHENIX Experiment at RHIC:

Stony Brook University is the closest major University to Brookhaven National Laboratory, home of the Relativistic Heavy Ion Collider. Stony Brook is a founding member of the PHENIX collaboration and has leading contributions to construction (PHENIX RICH, PHENIX Drift Chambers, PHENIX HBD, PHENIX VTX), management, and physics analyses investigating QGP and its properties and the origin of nucleon spin using jets, direct photons, di-leptons mesons. The breadth of our interests and proximity to the experiment leads to a broad experience for all graduate students.

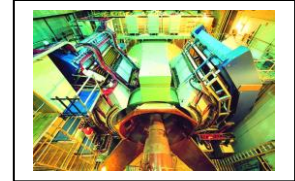

Website: www.phenix.bnl.gov

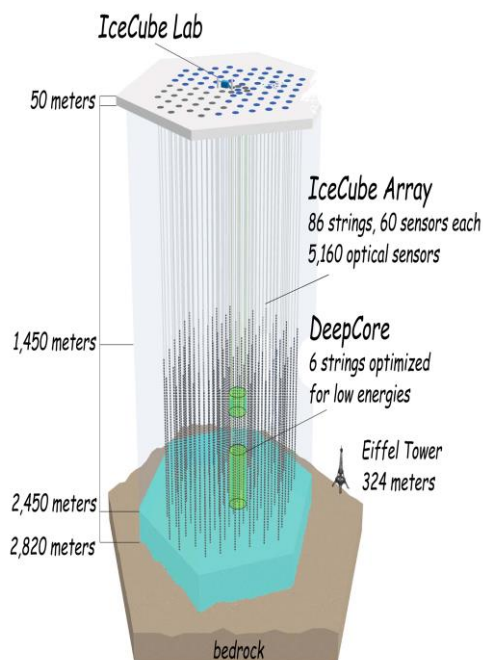

Ice Cube @ South Pole:

IceCube is a particle detector at the South Pole that records the interactions of a nearly massless sub-atomic particle called the neutrino. IceCube searches for neutrinos from the most violent astrophysical sources: events like exploding stars, gamma ray bursts, and cataclysmic phenomena involving black holes and neutron stars. The IceCube telescope is a powerful tool to search for dark matter, and could reveal the new physical processes associated with the enigmatic origin of the highest energy particles in nature. In addition, exploring the background of neutrinos produced in the atmosphere, IceCube studies the neutrinos themselves; their energies far exceed those produced by accelerator beams. IceCube is the world's largest neutrino detector, encompassing a cubic kilometer of ice.



Website: icecube.wisc.edu



About Stony Brook:

Stony Brook is located centrally on Long Island. Cultural experiences of all sorts are a short train or car ride away, New York City to the west, beaches on the Atlantic Ocean to the south, peaceful vineyards to the East.

Graduate Studies in Nuclear Science at Texas A&M University

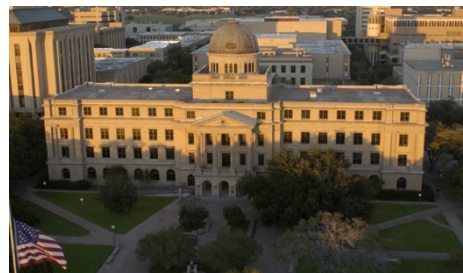

DEPARTMENTAL WEBSITES

physics.tamu.edu

chem.tamu.edu

NUCLEAR PEOPLE

| | |
|--------------------------|----|
| Experimental Faculty | 12 |
| Theoretical Faculty | 7 |
| Physics Faculty | 16 |
| Chemistry Faculty | 3 |
| Female Faculty | 3 |
| Graduate Students | 29 |
| Female Graduate Students | 6 |

APPLICATION WEBSITES

Physics: www.ApplyTexas.org

Chemistry: www.ApplyTexas.org

APPLICATION DEADLINES

Physics

Domestic: December 1

International: December 15

Chemistry

All Students: December 15

CONTACT IN NUCLEAR SCIENCE

Prof. Che-Ming Ko

Cyclotron Institute

Texas A&M University

TAMU 3366

College Station, TX 77843-3366

+1-979-845-1411

Ko@comp.tamu.edu

General Information

Texas A&M University was founded in 1876 as the Agricultural and Mechanical College of Texas, the first institution of higher learning in the state. At that time, the all-male student body focused on training in military and agricultural sciences. Today, A&M is a comprehensive, coeducational institution offering degrees in over 130 undergraduate fields and 260 master's and doctoral programs.

The university prides itself on its sense of tradition and service, with many undergraduate students joining the Corps of Cadets, an enduring symbol of the university. Of the 64,000 students, 22,000 volunteer in the "Big Event," the largest one-day, student-run service project in the nation.

Nuclear Physics and Chemistry Research Areas

Fundamental Interactions

Giant Resonances

Heavy Element Chemistry

Theoretical Nuclear Physics

High-Energy Nuclear Physics

Nuclear Astrophysics

Nuclear Reactions and Thermodynamics

Spin Physics

Other Broad Research Areas in the Departments

Astronomy and Astrophysics

Biochemistry and Biological Chemistry

High-Energy Physics Experiment and Theory

Low-Temperature and Condensed Matter Physics

Natural Product and Supramolecular Chemistry

Organic and Organometallic Chemistry

Quantum Optics and Atomic Physics

Spectroscopy and Mass Spectrometry

Texas A&M University



Cyclotron Institute

Cyclotron Institute

The Texas A&M University Cyclotron Institute is a leading nuclear science research facility, with a broad range of activities. Funded primarily by the Department of Energy and the Robert A. Welch Foundation, the Institute operates two cyclotrons. The K500 superconducting cyclotron delivers intermediate-energy beams of heavy ions for experiments in radioactive beam production, multifragmentation, and nuclear astrophysics. The K150 normal-conducting cyclotron is being recommissioned to provide very intense, low-energy beams and will be the driver for a reaccelerated radioactive beam program under development.

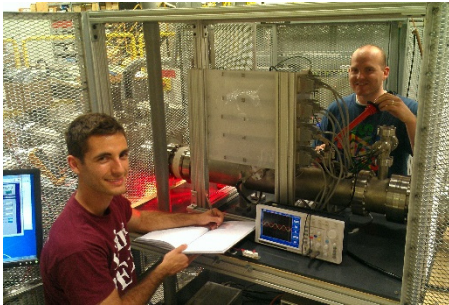

TAMUTRAP Cooler/Buncher

Instrumentation available at the Institute includes the MARS recoil spectrometer, the MDM broad-range spectrometer, an ion interactions line, the NIMROD array for neutrons and charged particle identification, the FAUST array for isotopic identification, a fast-tape transport system and decay station, and a radiation effects facility. Theoretical research is focused in the areas of low-energy nuclear reactions, high-energy nuclear collisions, the quark-gluon plasma, and nuclear astrophysics.

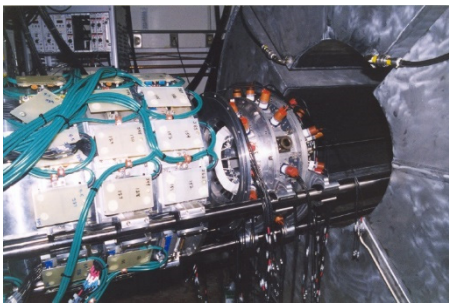

NIMROD

Among the 19 faculty members, three are Distinguished Professors at the university and eight are Fellows of the American Physical Society. Individual faculty members have won the American Chemical Society Glenn T. Seaborg Award, the Humboldt Research Award, the NSF CAREER Award, the American Physical Society Maria Goeppert Mayer Award, the IUPAP Young Scientist Prize, and the DOE Early Career Award.

Institute faculty and staff have begun working with members of the Nuclear Engineering department on issues related to isotope production and nuclear forensics. This is part of a broader effort toward coordinating the university's entire nuclear research program, including fundamental research, applied research, and nuclear policy.

VISIT US ONLINE AT

cyclotron.tamu.edu



About College Station

Texas A&M University is situated in southeast Texas, centrally located near the greater Houston, Austin, Dallas/Ft. Worth, and San Antonio metropolitan areas. 80% of Texas' population lives within a 200-mile radius of College Station. Winters are mild and the area averages over 200 sunny days per year. Combined with the neighboring city of Bryan, the area has a population of over 175,000 and offers a high quality of life with a moderate cost of living. There are numerous opportunities to enjoy outdoor activities, performing arts, and sporting events.

Graduate studies in Nuclear Physics at Temple University



Nuclear Physics Group:

Experimental Faculty 5

- Jeff Martoff
- Zein-Eddine Meziani
- Jim Napolitano
- Nikos Sparveris
- Bernd Surrow

Theoretical Faculty 2

- Martha Constantinou
- Andreas Metz

Research Faculty 2

Postdoctoral Fellows 6

Graduate Students 16

Departmental web site:

<https://phys.cst.temple.edu/>

Application site:

<https://phys.cst.temple.edu/apply.html>

Application Deadline:

January 15, 2017

Admissions committee chair:

Professor Xifan Wu

(215) 204-7627

xifan.wu@temple.edu

<https://phys.cst.temple.edu/xifan-wu.html>

General Info:

Temple University is located in Philadelphia, PA. Temple University's 17 schools and colleges, nine campuses, hundreds of degree programs and more than 37,000 students combine to create one of the most comprehensive and diverse learning environments in the USA.

Nuclear physics research areas:

Nucleon structure

Nuclear few-body systems

Hadron spectroscopy and structure

Electroweak interactions

Neutrinos

Fundamental symmetries

High-energy collider physics of strong interactions

Dark matter

Lattice gauge theories

Physics beyond the Standard Model

About the Physics Department:

The Physics Department was recently relocated to a new \$150-million facility, the Science Education and Research Center (SERC) building. Other broad research areas in the department involve condensed matter physics, and atomic, molecular and optical physics.

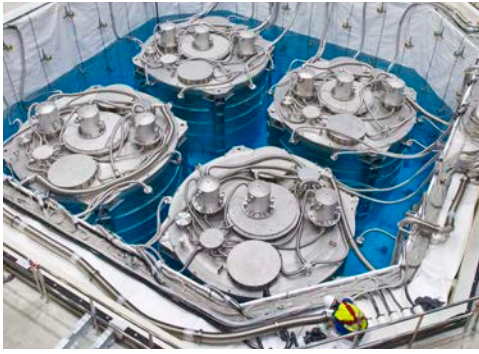

The Daya Bay Neutrino Experiment



Jefferson Lab's Experimental Hall A

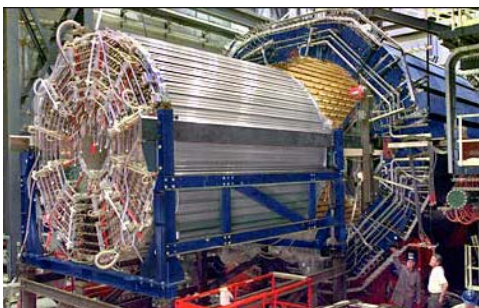

The STAR Detector at BNL



Darkside

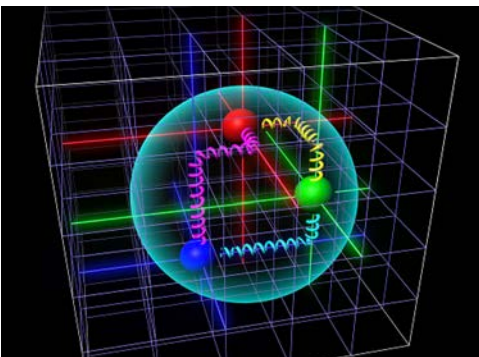

Proton on the Lattice

Experimental Nuclear Physics Research:

Fundamental symmetries, neutrino interactions, and elementary particles. Current research projects include the measurement of neutrino oscillations at the Daya Bay Nuclear Power Plant, a search for sterile neutrinos at the High Flux Isotope Reactor at Oak Ridge National Laboratory, and precision electroweak scattering experiments.

Study of the nucleon structure and of the few-body nuclear systems at the Thomas Jefferson National Accelerator Facility (Jefferson Lab), at the MAMI Microtron in Germany, and at PSI in Switzerland. Current research projects focus on the spin structure of the nucleon, on the nucleon mass budget, on the nucleon properties in the nuclear medium, on the Generalized Polarizabilities of the proton, the study of the excitation mechanism of the nucleon, and the proton radius puzzle.

Temple University is leading a program at the Brookhaven National Laboratory on gluon polarization measurements and a program studying the production of W bosons to deepen our understanding of the QCD sea.

Particle astrophysics, including dark matter searches like the DarkSide-50 liquid argon time projection chamber which is taking data at the underground laboratory LNGS in Italy, searches for dark-matter like particles with the DarkLight experiment, and x-ray polarimetry with gas-based tracking detectors to explore strong-gravity objects in space.

Theoretical Nuclear Physics Research:

Physics of the strong interaction and parton structure of hadrons: The research includes studies of form factors, parton distributions, 3-D imaging of strongly interacting systems, etc. Conceptual and phenomenological methods are used. The work is related as well as complementary to experimental efforts at high-energy particle accelerators.

Large scale simulations of Lattice QCD to study the strong interactions that bind quarks and gluons together to form the nucleons, the fundamental constituents of the visible matter. Open questions related to hadron structure are being addressed with numerical simulations performed on the biggest supercomputers.



Nuclear people

| | |
|----------------------------|----|
| Experimental Faculty | 8 |
| Theoretical Faculty | 3 |
| Graduate Students | 29 |
| Female Faculty | 3 |
| Female Grad Students..... | 6 |

Application deadline

February 1 to be considered for financial support

General university, department, and admissions information

www.aip.org/gpb/pdf_files/232.pdf

Departmental website

www.phys.utk.edu

Application site

gradschool.utk.edu/admissions/

Contact in Nuclear Physics

Dr. Kate Jones
Associate Professor
Associate Department Head
Experimental Nuclear Physics
kgrzywac@utk.edu
865-974-4022

General information

Founded in 1794 as Blount College, the University of Tennessee, Knoxville, became a land grant university in 1869. We offer more than 300 degree programs for our students, who enjoy a first-class research library and a technology-rich infrastructure. The university is a co-manager with Battelle of the nearby Oak Ridge National Laboratory (ORNL), where faculty and students experience unparalleled research and learning opportunities at the Department of **Energy's** largest science and energy lab. For FY 2014 UT garnered \$140 million in sponsored research awards. We serve more than 21,000 undergraduates and nearly **6,000 graduate students**. Our campus and its signature "Hill" lure students with green space, nearby lakes, and vistas of the Great Smoky Mountains National Park.

Nuclear physics research areas

Fundamental Neutron Physics
Hadron Structure
Nuclear Astrophysics
Nuclear Structure
Relativistic Heavy Ion Physics

Other broad research areas

Astrophysics
Biophysics
Condensed Matter Physics
High Energy Physics

Our program

Nuclear physics is a strong and active research group at UT Knoxville, taking advantage of close connections with ORNL and access to leading computational facilities.

T PHYSICS & ASTRONOMY

The nuclear theory group at UT performs world-class research in ab-initio methods for nuclear structure, chiral effective theory, few-body systems, and nuclear astrophysics. Theory has recently received funding from SciDAC, a DOE Topical Collaboration, and two NSF Career awards.

Experimentalists test nuclear many-body theories at extreme conditions measuring the properties of nuclei and nucleonic matter with accelerated stable and radioactive ion beams at national facilities. The Relativistic Heavy Ion Physics group is part ALICE at CERN and the PHENIX collaboration at Brookhaven National Laboratory, where heavy nuclei collide at extremely high energies to yield matter that is not only the hottest and densest ever explored, but is also **the world's most perfect liquid**. Experiments in nuclear astrophysics give insight into the nuclear reactions in stars, essential for understanding the conditions whereby chemical elements are synthesized by nuclear processes. Fundamental symmetries experiments study the nature of the neutrino through neutrinoless double beta decay.

A beamline at the Spallation Neutron Source allows scientists to study neutron beta decay and parity violation, and to search for the neutron electric dipole moment. Jefferson Laboratory in Virginia has recently completed a substantial energy and equipment upgrade. The nuclear physics group uses the 12 GeV electron facility to study modification of protons in nuclei, the quark substructure of nuclei, as well as dense and energetic components of nuclei.

The nuclear physics group has also developed new technologies to analyze the decay of radioactive nuclei relevant for nuclear energy and astrophysical nucleosynthesis in strong partnership with scientists from the Physics Division at ORNL. The **university's connection with ORNL** is exemplified by the Joint Institute for Nuclear Physics and Applications (JINPA), a partnership that also includes Vanderbilt University, to foster close collaborations between academic and national laboratory scientists. JINPA supports nuclear structure theory with links to experiment.

About Knoxville

Nestled along the Tennessee River, Knoxville has a prime location near outdoor wonders like the Great Smoky Mountains National Park, the Ocoee River, and the Big South Fork National River and Recreation Area. The city boasts a vibrant history that has been captured in the works of nationally renowned poets, writers, and artists, including James Agee, Cormac McCarthy, Quentin Tarantino, and Nikki Giovanni. To learn more about Knoxville, visit www.knoxville.org.



Graduate Student Joel Mazer (front) and David Silvermyr at CERN.

Scientific Partnerships

- Oak Ridge National Laboratory Physics Division
- Spallation Neutron Source
- Joint Institute for Nuclear Physics and Applications
- Center of Excellence for Ion Beam Studies for Stewardship Science
- Japan-U.S. Institute for Physics with Exotic Nuclei

Graduate Studies in Nuclear Physics at **Tulane University**



Nuclear People:

| | |
|-----------------------|---|
| Experimental Faculty: | 1 |
| Theoretical Faculty: | 1 |
| Postdocs: | 1 |
| Graduate Students: | 5 |

Application deadline:

February 1st

Departmental web site:

www.physics.tulane.edu

Application site:

<http://tulane.edu/sse/academics/graduate/admissions.cfm>

Contact:

Fred Wietfeldt
(504)862-3175
few@tulane.edu

General Info:

Founded in 1834 in New Orleans, Tulane is one of the most highly regarded and selective independent research universities in the southern United States. Its schools and colleges offer undergraduate, graduate and professional degrees in the liberal arts, science and engineering, architecture, business, law, social work, medicine and public health and tropical medicine.

The on-campus enrollment at Tulane University for the 2015 fall semester was approximately 13,500 students, including 5110 graduate and professional students.

Famed for its history, music and cuisine, New Orleans is one of the world's most extraordinary cities. Unique neighborhoods reflect the city's French, Spanish and Caribbean roots. World-class museums display renowned artworks and artifacts. Shopping options range from vintage shops and antique stores to high-end boutiques and galleries. The educational experience at Tulane University is interwoven with this rich cultural tapestry.

Precision Neutron Decay Measurements:

Fred Wietfeldt



Decay of the free neutron into a proton, electron, and antineutrino is the prototype semileptonic weak decay. Observables of neutron decay such as the neutron lifetime and angular correlations are directly related to fundamental parameters of the weak interaction and important processes in Big Bang nucleosynthesis, cosmology, solar physics, and neutrino interactions. These experiments are carried out at the NIST Center for Neutron Research in Gaithersburg, MD.

Neutron Interferometry:

Fred Wietfeldt

A neutron interferometer splits the wave function of a single neutron into separate paths using Bragg reflection in a perfect crystal. These paths are recombined to form an interference pattern. Neutron interferometry is used to make precision measurements of neutron scattering lengths and for fundamental tests of quantum mechanics.

Theoretical Nuclear Physics:

George Rosensteel



In a quest for unity in physics across its fields, the theoretical researcher abstracts from particular phenomena to general physical principles. The process requires contemporary mathematical tools, including representations of non-compact Lie groups, geometric quantization, differential geometry of principal fiber bundles, and dynamical systems on co-adjoint orbits. With these tools we can model collective motion of objects whose sizes vary by orders of magnitude. My research program has been utilizing these methods in the construction of the symplectic model and in its applications to the theoretical description of geometrical collective modes in atomic nuclei and astrophysical systems.

Graduate Studies in Nuclear Physics at Vanderbilt University



Nuclear People:

| | |
|--|----|
| Experimental Faculty: | 5 |
| Theoretical Faculty: | 2 |
| Female Faculty: | 2 |
| Senior Research Associates and Post Doctoral Fellows: | 6 |
| Graduate students: | 10 |

Median Time to PhD:

5.4 years

Application deadline:

January 1

Department, and admissions information:

www.vanderbilt.edu/physics/
donald.pickert@vanderbilt.edu

Director of graduate studies:

Julia Velkovska
julia.velkovska@vanderbilt.edu

Contacts:

A. V. Ramayya, Structure
a.v.ramayya@vanderbilt.edu
Julia Velkovska, RHIC and LHC
julia.velkovska@vanderbilt.edu
Sait Umar, Theory
sait.a.umar@vanderbilt.edu



General Info:

Vanderbilt University is a private research institution located in Nashville, Tennessee. Ten colleges and schools are home to 6,883 undergraduate and 5,722 graduate and professional students. With a student-faculty ratio of approximately 2:1, the Department of Physics and Astronomy offers the opportunity to work closely with world-class faculty on forefront research using state-of-the-art tools.

Nashville is a cosmopolitan city of 700,000 residents. Named by *The Today Show* as one of America's top-five friendliest cities, Nashville is home to an incredible range of cultural and entertainment offerings, from the *Schermerhorn Symphony Center* and the *Frist Center for the Visual Arts*, to the *Grand Ole Opry* and the *Tennessee Titans*.

Nuclear physics research areas:

Fundamental interactions
Nuclear astrophysics
Nuclear reactions
Nuclear structure
Synthesis of superheavy elements
Relativistic heavy ion collisions
Quark-gluon-plasma physics

Major collaborations:

Nuclear Physics and its Applications, Oak Ridge
Joint Institute for Heavy Ion Research, Oak Ridge
PHENIX and sPHENIX experiments at the Relativistic Heavy Ion Collider (RHIC), Brookhaven National Laboratory
Compact Muon Solenoid (CMS) experiment at the Large Hadron Collider (LHC), CERN

Vanderbilt host a dedicated computing facility for the heavy-ion program of CMS

Vanderbilt leads consortium from China, Lawrence Berkeley National Laboratory, Russia and other universities to study fission and neutron-rich nuclei

Synthesis of new elements at Flerov Laboratory of Nuclear Reactions, Russia



Joint Institute, VU, UT, ORNL

Experimental Nuclear Structure: Research is carried out at Argonne National Laboratory, and National Superconducting Cyclotron Laboratory, and the Flerov Laboratory for Nuclear Reactions in Russia. The spontaneous fission of ^{252}Cf is used to study the fission process and neutron-rich nuclei with Gammasphere. A new isobar separator with resolution of 1/200,000 to 1/400,000 to open up currently inaccessible studies of n-rich nuclei has been developed for use with FRIB. In Russia, the group has been an important part of the synthesis of the new element with $Z=117$ and recent confirmation of 115 and 118. Over the next several years, these studies will include identification of isotopes of more neutron-rich superheavy elements and new elements beyond 118. This group has over 1000 research publications, has graduated over 60 Ph.D's, and organized thirteen international conferences, the next in 2016.

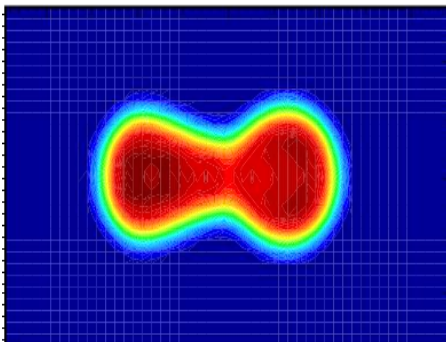

New shape isomeric states in actinides using TDHF method

Nuclear Theory: The nuclear theory group conducts research in the areas of low-energy nuclear reactions and in neutrino physics. This work is funded by DOE. Specifically, we study the structure and reactions of nuclei far away from the line of stability, in particular neutron-rich nuclei which will be accessible with radioactive ion beam facilities such as HRIBF and FRIB. Recently, we introduced the density-constrained TDHF method to describe fusion cross sections of heavy ions and new shape isomeric states in actinides with very large quadrupole deformation (see picture). We are also working on hot and cold fusion reactions in connection with superheavy element searches. The neutrino work concentrates on constructing computational tools for analyzing neutrino oscillation data. The most important of these is the analysis of the Super K atmospheric data.

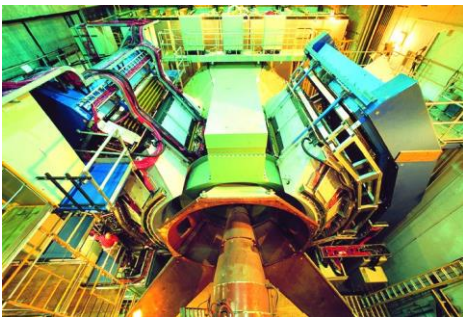

The PHENIX experiment at RHIC



CMS Detector at LHC at CERN, Geneva

Relativistic Heavy Ion Physics: The objective of relativistic heavy ion physics is to study nuclear matter under extremely hot and dense conditions and to understand quark confinement. Data from the PHENIX experiment at the Relativistic Heavy Ion Collider (RHIC) at Brookhaven National Laboratory suggest that high energy heavy ion collisions produce an equilibrated non-hadronic system, perhaps best described as a quark-gluon liquid with very small viscosity. Members of the group have played a leading role in all PHENIX publications in the areas of identified hadron spectral shapes, collective flow and particle production through hard-scattering, all topics essential to characterize this new state of matter. We are presently constructing a state-of-the art detector, sPHENIX, to study the quark-gluon plasma (QGP) with rare probes, such as jets and heavy quarkonia. At the same time, we are investigating QGP produced in the much higher energy domain of the Large Hadron Collider (LHC) in Geneva using data from the CMS detector. Our group is leading the physics studies of particle correlations and collective flow and has major responsibilities for computing in the heavy ion program of CMS.

Graduate Study in Nuclear Physics University of Washington, Seattle, WA



CENPA Faculty: 10
INT Faculty: 5
Nuclear Theory Faculty: 4
Graduate Students: 30

Application Date: Jan. 5
International: Nov. 1

General University Information:
www.washington.edu

Physics:
www.phys.washington.edu

Contact:
Prof. Alejandro Garcia
agarcia3@uw.edu

Graduate School Site:
<http://www.phys.washington.edu/grad.htm#phd>

Research Experiences for
Undergraduates (REU) Program:
www.int.washington.edu/REU/

The University of Washington is a major research university situated on a beautiful campus in Seattle in the Pacific Northwest. The UW – “U-Dub” – receives the second largest amount of federal research funding of all US universities. Six UW scientists have won Nobel Prizes, including our Hans Dehmelt, 1989 Nobel Laureate in Physics, now retired.

Nuclear Physics at UW:

The UW is a unique center for nuclear physics. It is home to the national Institute for Nuclear Theory (INT), and to the Center for Experimental Nuclear Physics and Astrophysics (CENPA), one of DOE’s Centers of Excellence. In addition a leading nuclear theory group exists within the Department of Physics. The Department of Physics, INT, and the Astronomy Department share a spacious new building, which encourages collaboration. CENPA has its own laboratories, including an FN tandem accelerator, in the North Physics Laboratory across campus.

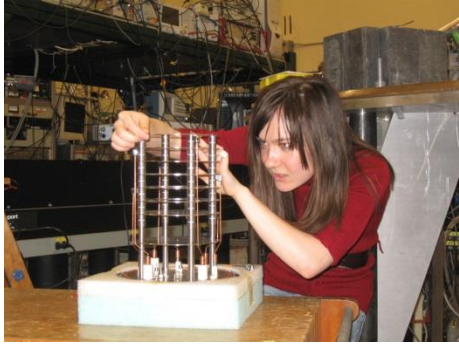

Graduate student adjusting ^6He time-projection chamber column.

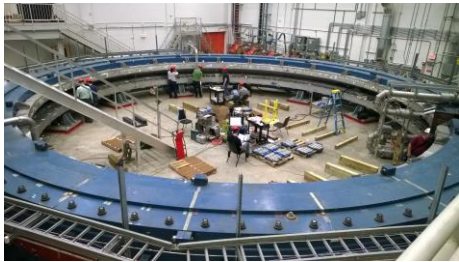

g-2 ring being commissioned at Fermilab.

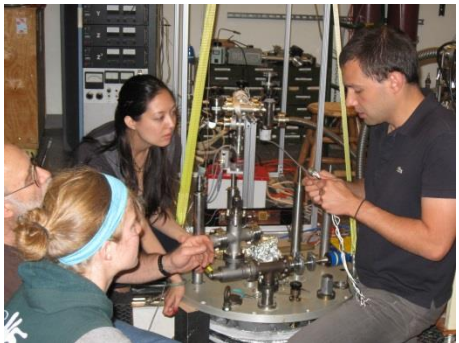

Graduate students and engineer working on Project 8 prototype.

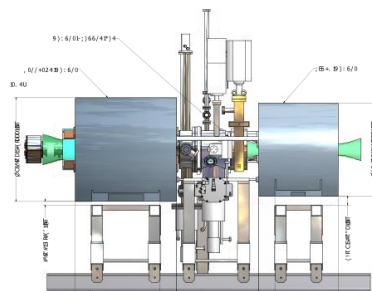

KATRIN detector system, with 2 6-T superconducting magnets.

General Information:

CENPA physicists played a major role in the SNO experiment that resolved the solar neutrino problem, showing it was caused by neutrino oscillations and mass. The research was recognized by the 2015 Nobel and Breakthrough Prizes. How large the mass is will be addressed by 2 projects, KATRIN, and a new idea called “Project 8.” The MAJORANA project searches for neutrinoless double beta decay, which would signal that neutrinos and antineutrinos are the same particle. CENPA physicists are spearheading two high-precision measurements involving muons. The New (g-2) Experiment at Fermilab will sensitively test the Standard Model and the MuSun experiment at the Paul Scherrer Institute will determine a central parameter in the theory of fundamental astrophysics processes. CENPA has developed the most intense source of radioactive ^6He atoms in the world to use in conjunction with laser traps to search for new physics that would be observable in beta decay. Delicate torsion balances are being used to explore such exotic issues as dark matter, axions, general relativity, and extra dimensions.

Nuclear theorists in the Department are addressing a wide range of problems, such as the use of fundamental QCD lattice-gauge theory to calculate the properties of real nuclei, and nuclear effects that must be understood to determine if the famous CKM matrix is unitary, or if there is physics beyond the standard model.

The Institute for Nuclear Theory hosts programs and workshops to advance the frontiers of nuclear science and its intersections with astrophysics, cosmology, condensed matter/ atomic physics and particle physics. These programs attract about 500 theorists from around the world each year. In addition, the INT faculty performs research on a similarly broad range of topics including strongly interacting many-particle systems such as nuclei, the quark gluon plasma and dense matter found inside neutron stars, nuclear and neutrino astrophysics, neutrino physics, and physics beyond the standard model.

Graduate Studies in Nuclear Physics at Washington University in St. Louis



Nuclear People

| | |
|----------------------------|---|
| Faculty (Experiment) | 2 |
| Faculty (Theory) | 2 |
| Research Faculty and Staff | 4 |
| Postdoc/Visitor | 2 |
| Students | 8 |

Departmental Websites

www.chemistry.wustl.edu
www.physics.wustl.edu

Application Deadline

Chemistry: Rolling
Physics: December 31

Application Sites

www.chemistry.wustl.edu
www.physics.wustl.edu

Contacts in Nuclear Physics

L.G. Sobotka, Experiment lgs@wustl.edu
W.H. Dickhoff, Theory wimd@wuphys.wustl.edu



Nuclear and radiochemistry teaching laboratory.

General Information

Washington University in St. Louis (WU) is a medium-sized, private university dedicated to challenging its students, faculty, and staff to seek new knowledge and greater understanding of an ever-changing world. The university is highly regarded for its commitment to excellence in learning. The on-campus enrollment at WU for the Fall 2010 semester was approximately 11,000, including 5,000 graduate students. WU has a long history in nuclear chemistry and physics research and has the best equipped nuclear and radiochemistry teaching laboratory in the nation.

The Nuclear Chemistry group, a group of experimentalists with diverse interests and expertise in novel detector development and instrumentation, and a theory group in the Physics Department perform basic nuclear science research.

Nuclear Chemistry and Physics Research Areas

Low-Energy Nuclear Structure
Low- and Medium-Energy Nuclear Reactions
Nuclear Many-Body Theory
Neutron Stars
Quark Matter
Instrumentation for Ionizing Radiation Detection

Related Research Areas at WU

High-energy Astrophysics
Lattice QCD
Space and Earth Sciences with Nuclear Methods
Imaging with Nuclear Methods
Radiochemistry

Washington University in St. Louis

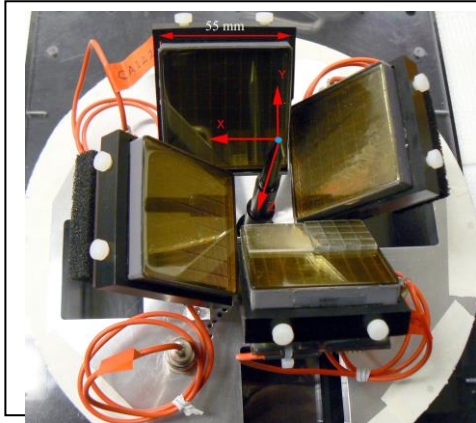

The Washington University Phoswich Wall, using two layers of scintillators ($\Delta E-E$) and multi-anode photomultiplier readout.

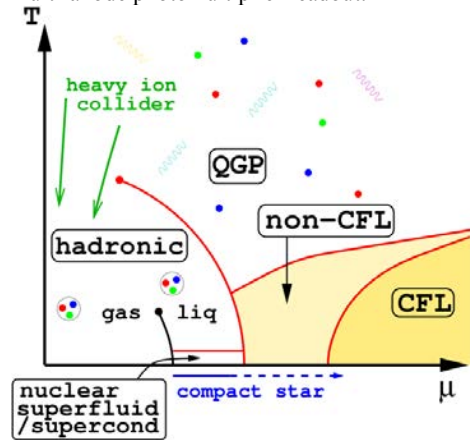

Phase diagram of dense matter



Detector used for four-body decay measurements. This small detector array is part of the larger HiRA array built in collaboration with MSU and IU. Images of two former students can be seen reflecting off the Si detectors.

Nuclear Structure: Shapes and Shell Effects

Experiments with heavy-ion beams and certain target isotopes allow to excite heavy nuclei, e.g. ^{145}Xe , and study their shape and structure. In this example, evolution of shell structure with neutron number is of interest. The experiments will be using inverse-kinematics transfer reactions or Coulex and aim at extracting spectroscopic information for the product nucleus. They require combining a particle detector with the γ -ray spectrometers Gretina or Gammasphere. The particle detector, Phoswich Wall, has large forward-angle coverage and enhances the performance of the γ -ray spectrometers, which are available at national laboratories.

Theory of nuclei, neutron, nuclear and quark matter

Prof Alford works on the properties of ultra-dense matter, of the type that might be found in the center of neutron stars, where gravitational forces squeeze matter to many times nuclear density. One of the main topics is quark matter, which is expected to exist when the density is so high that neutrons and protons are crushed into a liquid of quarks. This research involves a cross-fertilization of ideas from nuclear physics, particle physics, astronomy, and condensed matter physics. Prof Dickhoff applies *ab initio* Green's function methods to nuclei that include the influence of correlations on the properties of nucleons. The method also provides a framework for the analysis of elastic nucleon scattering and level data in the form of the dispersive optical model. This project involves both theorists and experimentalists and is important for FRIB.

Reactions Studies of Nuclear Properties

A broad range of types and energies of nuclear reactions are used to probe correlations of nucleons in nuclei and nuclear structure research. To explore the dependence of correlations with large asymmetries of neutrons to protons and vice versa, we utilize proton and neutron elastic scattering measurements, total and reactions cross section measurements, nucleon knockout and transfer reactions. These measurements have been performed at Michigan State University (NSCL), Los Alamos (LANSCE), and Duke University (TUNL). The WU group also has an extensive to study the continuum structure of light, and often very exotic, nuclei. This structure frequently has astrophysical relevance. This experimental program is carried out at Texas A&M (TAMU) and the NSCL using detectors and techniques developed at locally.



Graduate Studies in Nuclear Physics at Wayne State University

Nuclear Group:

Experimental Faculty:
 Theoretical Faculty:
 Postdoctors/Research Fellows:
 Graduate Students:
 Undergraduates:
 Female Students:

4
2
6
11
4
3

Median Time to PhD:

5 years

Application deadline:

January 1st to be considered for fellowships

General university, and admissions information:

<http://wayne.edu/>

Application site:

<http://apply.wayne.edu/>

Departmental web site:

<http://physics.clas.wayne.edu/>

Nuclear Group Website:

<http://rhig.physics.wayne.edu/>

Contact in Nuclear Physics:

Prof. Claude Pruneau
 (313) 577-1813
claude.pruneau@wayne.edu

General Information:

WAYNE STATE UNIVERSITY is one of the three constitutionally autonomous state universities in Michigan and holds the Carnegie Research RU/VH (very high research activity) University status. This select group of comprehensive universities offers a broad range of baccalaureate programs while demonstrating a commitment to graduate education and a significant capacity for research. Our 30000+ students study in 15 colleges and schools with more than 40 percent of the student body enrolled in graduate and professional programs. WSU offers 355 major subject areas, 128 bachelor, 136 master, and 61 different doctoral degrees plus 30 different certificates, specialist and professional programs.

Recognized for the beauty and uniqueness of its architecture, and its very safe and secure environment, the Wayne State University main campus encompasses more than 200 acres of beautifully landscaped and tree-lined malls and courts, which are accentuated by lovely arcades, sculpture courts, fountain, pools, and gardens linking 94 education and research buildings. These buildings are of both classic and contemporary design, including some of Minoru Yamasaki's best-known buildings. A recreation and Fitness Center in the center of the campus is available for the enjoyment of students and faculty.

Nuclear physics research areas:

Fundamental interactions
 Nuclear reactions
 Heavy Ion Physics

Other broad research areas in department:

Astronomy and astrophysics
 Condensed matter physics
 Elementary particle physics

Wayne State University



Relativistic Heavy Ion Group

Members of our group have continuing involvement in relativistic heavy ion experiments at Brookhaven National Laboratory and CERN. They were involved in BNL-AGS experiments E814, E877, E864, E896, E941, and CERN experiment NA49 now completed. Members of the group currently participate in the STAR experiment at Brookhaven National Laboratory, as well as the ALICE experiment at the CERN Large Hadron Collider. The primary physics goal of these two experiments is to study the formation and characteristics of the quark-gluon plasma (QGP), a state of matter that exists at extremely high temperature and density. Study of the QGP enables a better understanding of the basic constituents of matter and the state of the universe moments after the Big Bang. It is produced via collisions of heavy nuclei, and studied with large detectors that enable measurements of the many thousands of particles produced in these collisions.

ALICE Collaboration

The ALICE Collaboration operates a dedicated heavy-ion detector to exploit the unique physics potential of nucleus-nucleus interactions at LHC energies. The ALICE - USA collaboration contributed to the ALICE experiment with the construction of a large electromagnetic calorimeter (EMcal). The EMcal and other ALICE detectors enable the study of strongly interacting matter at extreme energy densities, and more specifically investigations of a new phase of matter, the quark-gluon plasma, is expected.

Theory Group

The two leading theoretical methods to study this exotic state of matter are based on computational fluid dynamics simulations of the dense matter created in these collisions and the study of hard jets: collimated bundles of energy formed in these collisions that burrow through the QGP. Members of the theory group carry out calculations involving both fluid dynamics as well as simulations of hard jets modified by passage through the plasma. These calculations support the missions of STAR and ALICE, as well as those of the PHENIX experiment at RHIC, and the CMS and ATLAS experiments at the LHC.

JETSCAPE Collaboration

The Jet Energy-loss Tomography with a Statistical and Computationally Advanced Program Envelope (JETSCAPE) collaboration is a multi-disciplinary, multi-institutional collaboration of theoretical physicists, experimental physicists, computer scientists and statisticians involving Duke, Lawrence Livermore National Lab., MIT, McGill, Ohio State, Texas A&M, UC Berkeley and Wayne State. Funded by the NSF, this collaboration, led by Wayne State, will carry out the development of the next generation of event generators, that will simulate every aspect of the expanding exploding QGP formed in a heavy-ion collision, with an emphasis on jets and statistical tools to discern the validity of all future theory developments in this field.

About Detroit:

Wayne State University is located in the heart of Detroit, just minutes away from the downtown area, and in close proximity to many nearby cities including Chicago, and Toronto. Four full seasons can be experienced in Southern-Michigan, including warm summers and snowy winters. Detroit is a multiethnic city, and features a broad mix of cultural, musical, and artistic events.

Graduate Studies in Nuclear Physics at The College of William and Mary



Nuclear and Neutrino Group:

| | |
|---------------------------|----|
| Experimental Faculty: | 11 |
| Theoretical Faculty: | 5 |
| Postdoctoral Researchers: | 6 |
| Graduate Students: | 31 |
| Female Students: | 7 |

Rankings (US News and World Report):

W&M ranked 6th amongst public US universities

Physics Department Statistics:

Average annual number of Ph. D. recipients: 8
Average time to Ph. D.: 5 years

Departmental Website:

<http://www.wm.edu/physics>

<http://www.wm.edu/as/physics/research/index.php>

Graduate Admissions:

<http://www.wm.edu/as/physics/grad/index.php>

Application deadline: Feb 1st

Contact in Nuclear Physics:

Prof. David Armstrong

armd@physics.wm.edu

757-221-3289



William Small Physical Laboratory

General Information:

The College of William and Mary (W&M), chartered in 1693, is the second oldest university in the US. It boasts four US presidents, supreme court justices and Jon Stewart as alumni. W&M is a liberal arts university with a strong research focus. Our 7,800 students (2,000 of them graduate students) enjoy a low student-to-faculty ratio, state-of-the-art facilities, and a beautiful campus.

Located in Williamsburg, Virginia, W&M is in the heart of colonial American history and is adjacent to Colonial Williamsburg, a historic recreation of 18th century colonial life. While much of the campus has been restored to its 18th-century appearance, the physics department is housed in a newly refurbished and expanded building that provides outstanding teaching and research space.

The William and Mary physics department benefits enormously from close ties with both Thomas Jefferson National Accelerator Facility (JLab) and NASA Langley Research Center in nearby Newport News (thirty minutes from the W&M campus). In medium energy nuclear physics, JLab offers unparalleled facilities for research and training of our students. Several W&M faculty have joint positions at JLab and several JLab scientists have roles at W&M.

The physics department also has a strong program in both theoretical and experimental high-energy physics. The experimental high-energy program concentrates on neutrino physics and is involved in both accelerator-based (MINOS, NOvA, and MINERvA experiments at Fermilab) and reactor-based (Daya Bay) projects.

Research Areas

Atomic, Molecular and Optical Physics
Condensed Matter Physics
High Energy Physics
Nonlinear and Plasma Physics
Nuclear and Hadronic Physics



Qweak experiment @ JLab



MINOS detector @ Soudan Mine



³He target lab @ W&M

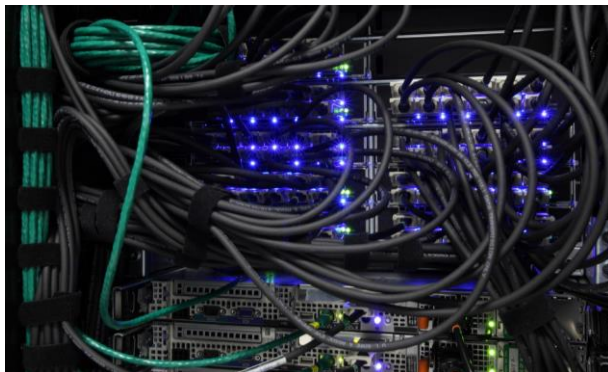

Lattice QCD computers @ W&M

Experimental Hadronic Physics

Our experimental research program centers is focused on research at JLab and graduate students spend much of their time their after the first two years of study. Our core research program centers on four areas: studies of strange quark form-factors in the nucleon via parity violation, nucleon spin-structure experiments using polarized targets developed at W&M, nucleon electromagnetic form factors, and precision searches for physics beyond the Standard Model via the weak interaction.

We are actively involved in the QWeak, G0, HAPPEX, PVDIS, SoLID, and MOLLER experiments, in the transversity and polarized ³He programs in Hall A, in the electromagnetic form factor and two-photon exchange programs in Hall A and C, in deep-inelastic scattering experiments with the SuperBigBite spectrometer in Hall A, and the CLAS12 collaboration.

Our faculty also actively collaborate on experiments in Mainz, Oak Ridge, TRIUMF, HIγS and on the development of a planned Electron-Ion Collider.

Experimental Particle Physics

At W&M we are studying neutrino oscillations using an accelerator-produced neutrino beam and the MINOS and NOvA detectors at Fermilab. We also searching for oscillations using anti-neutrinos produced by nuclear reactors at Daya Bay in China. Because neutrinos only couple to the weak nuclear force, their interactions with matter are not well measured and understood. We are conducting an experiment at Fermilab, MINERvA, which will make high precision measurements of neutrino cross-sections to support oscillation experiments and will also measure nucleon/nuclear structure in a way that's complementary to the electron scattering measurements made at Jefferson Lab.

Theoretical Nuclear and Particle Physics

Research in theoretical nuclear and particle physics focuses on understanding aspects of the Standard Model and beyond using a variety of tools.

Using large scale numerical computations to solve the equations of QCD (quantum chromodynamics, the theory of the strong force), our lattice QCD group probes the emergence of hadrons and nuclei from quarks and gluons, and seeks to determine important hadronic inputs in searches for physics beyond the Standard Model. These calculations utilize our on-campus cluster computers and also run on the biggest supercomputers in the country. Recent work includes studies of the strong decays of bottom baryons and the first QCD calculation of a nucleus.

We also engage in phenomenological studies of hadrons using tools such as AdS/QCD and other models. Recent work has highlighted the role of two-photon exchange contributions to nucleon form-factors and examined the transverse charge distributions of quarks inside the proton.



Faculty:

| | |
|---------------------------|-----|
| Total Faculty | 44 |
| Graduate Students: | 180 |
| Female faculty: | 6 |
| Female graduate students: | 32 |

Rankings :

#17 Physics Graduate program, U.S. News & World Report

Application deadline:

December 15

General university, department, and admissions information:

www.wisc.edu

http://www.aip.org/gpb/pdf_files/grd123.pdf

Departmental web site:

www.physics.wisc.edu

Application site:

<https://www.gradsch.wisc.edu/eapp/eapp.pl>

Contact:

Renee Lefkow

608.262.9678

physgrad@physics.wisc.edu

www.physics.wisc.edu

Graduate Studies in Nuclear Physics at

The University of Wisconsin-Madison

General Info:

The University of Wisconsin is a world-class university, nationally and internationally recognized for our academic excellence, incredible students, inspiring faculty, exceptional value, and an amazing campus and community. We invite you to learn more about UW–Madison and our academic programs, admission process, costs and financial aid, campus visits and more.

The tremendous breadth of academic programs at UW-Madison offers students a wide selection of supporting course work and interdisciplinary opportunities. 157 majors offer master's degrees and 110 majors offer doctorate degrees. More than 30,000 doctorates have been awarded by UW-Madison! UW-Madison ranks as one of the most prolific research universities in the world, placing second among American public universities for research expenditures.

The campus rolls along Lake Mendota, with wooded hills and the busy city streets of downtown Madison. Madison is small enough to navigate easily, but with cultural resources and amenities that rival those of cities many times its size.

Nuclear physics research areas:

Nuclear Theory Reaction theory; scattering theory; nuclear structure; many-body theory; symmetry principles; heavy ions and intermediate energies; high energy nuclear physics; nuclear astrophysics, neutrino physics. Nuclear astrophysics; neutrino physics.

Graduate Studies in Nuclear Physics at Yale University

Yale

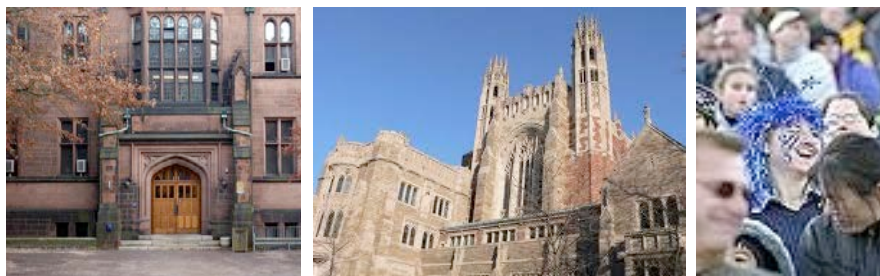

Yale Wright Laboratory & Nuclear Physics

| | |
|-----------------------|----|
| Experimental Faculty: | 12 |
| Theoretical Faculty: | 2 |
| Postdocs/Researchers: | 8 |
| Graduate Students: | 22 |

Rankings

#6 Graduate Nuclear Physics Program,
2014 *U.S. News & World Report*

Application deadline

January 2

Wright Lab and Physics Department

wlab.yale.edu

physics.yale.edu

Application site

www.yale.edu/graduateschool/admissions

General university, department, and admissions information

www.yale.edu/physics/graduate

Contact in Nuclear Physics

Prof. Karsten Heeger
Director, Yale Wright Laboratory
(203) 432-3078
Karsten.Heeger@yale.edu
heegerlab.yale.edu

General Information

Yale University, a university with honored traditions, was founded in 1701, and is not only a major research university but also one of the world's great universities. Some 11,000 students come from all the 50 states and from 108 countries. The 3,200-member faculty is a richly diverse group of men and women who are leaders in their respective fields. The central campus now covers 310 acres (125 hectares). Yale's buildings, towers, lawns, courtyards, walkways, gates, and arches comprise what one architecture critic has called "the most beautiful urban campus in America." The University also maintains over 600 acres (243 hectares) of athletic fields and natural preserves just a short walk or bus ride from the center of town. Led by a distinguished faculty, Yale carries out its education and research on the graduate level in eleven graduate and professional schools.

Nuclear physics research areas

Weak interaction, neutrinos, and
fundamental symmetries
Relativistic heavy ion physics
Nuclear structure
Nuclear theory

Other broad research areas in department

Astronomy and astrophysics
Condensed matter physics
Elementary particle physics
Atomic, molecular and optical physics
Biophysics

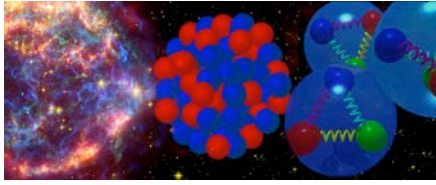

Yale Wright Laboratory

Research groups in the [Yale Wright Laboratory](#) study weak interactions and fundamental symmetries as well as the structural evolution of the atomic nucleus. Yale has a leading role in experiments that probe the nature of neutrinos through neutrinoless double beta-decay ([CUORE](#), [EXO](#)), study neutrino oscillations ([Daya Bay](#), [PROSPECT](#)), and measure the neutrino mass ([Project 8](#)). Yale researchers seek to identify the nature of dark matter through direct detection experiments ([DM-Ice](#)), astrophysical observations ([IceCube](#)), and axion searches ([ADMX-HFX](#)). Precision measurements of electric dipole moments ([EDM](#)) are used to search for physics beyond the Standard Model. The neutrino and dark matter experiments are located in underground laboratories worldwide ([LNGS](#), [Sanford](#), [Daya Bay](#), [Southpole](#)).

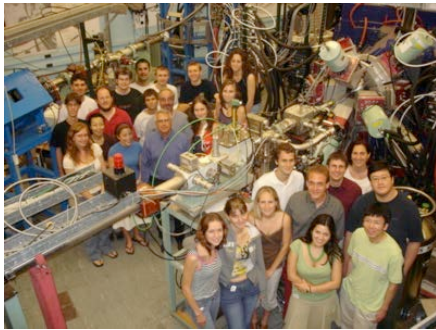

The nuclear structure group studies the structural evolution of the atomic nucleus with proton and neutron number, the interplay of single particle motions and interactions with collective modes, symmetries of the many-body system, quantum phase transitions in nuclear shapes, critical point descriptions, the proton-neutron interaction, and heavy nuclei. The research is carried out at a number of facilities worldwide.

<http://wlab.yale.edu>

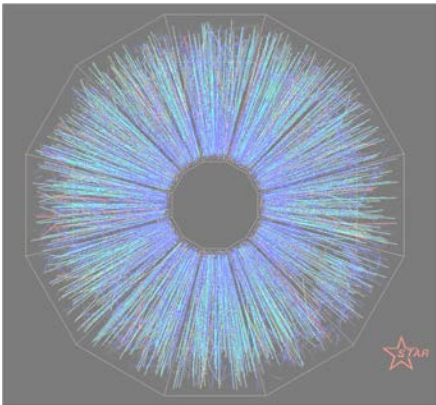

Relativistic Heavy Ion Physics

The research activities of the Relativistic Heavy Ion Group at Yale involve experimental research on the [STAR](#) experiment at the Relativistic Heavy Ion Collider ([RHIC](#)) at Brookhaven National Laboratory ([BNL](#)) on Long Island, New York, and on the [ALICE](#) experiment with heavy ions at the Large Hadron Collider ([LHC](#)) located at the Center for European Nuclear Research ([CERN](#)) in Geneva, Switzerland. Both experiments seek to form and investigate hot, dense QCD matter (the [QGP](#)) at several trillion degrees (Kelvin) absolute temperature.

<http://rhig.physics.yale.edu>

About New Haven



New Haven has been home to Yale University for nearly three centuries. As a center for business and a Mecca for the arts, New Haven is recognized as a city of innovation, culture and prosperity. Approximately 20 square miles with nearly 130,000 residents, New Haven is conveniently located between Boston and New York.

<http://www.infonewhaven.com/content/about-new-haven>